



# City of Santa Clarita

# **BUILDING CODE**

**Enforceable January 1, 2020**

## **Adopting the 2019 California Building Standards Code with City Amendments**

This document contains the following titles of the Santa Clarita Municipal Code:

- TITLE 18 - CITY BUILDING CODE
- TITLE 19 - CITY ELECTRICAL CODE
- TITLE 20 - CITY PLUMBING CODE
- TITLE 21 - CITY MECHANICAL CODE
- TITLE 22 - CITY FIRE CODE
- TITLE 24 - CITY ENERGY CONSERVATION CODE
- TITLE 25, CHAPTER 25.01 - CITY GREEN BUILDING CODE

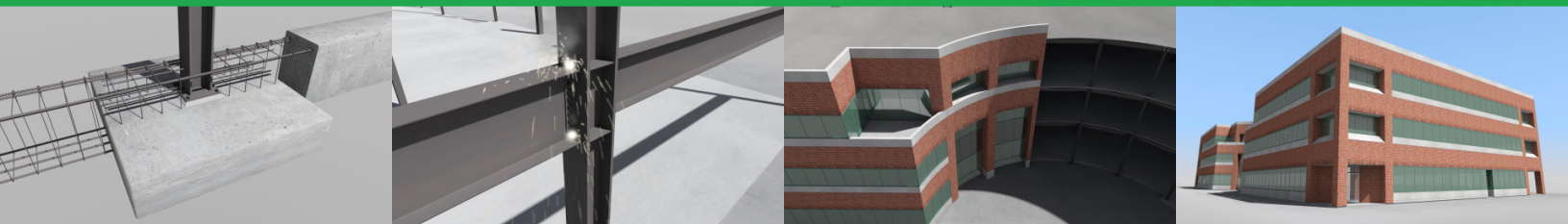

## **Title 18**

### **CITY BUILDING CODE**

#### **Chapters:**

- 18.01 Adoption of the City Building Code**
- 18.02 Amendments to CBC Chapter 1 Division II; Scope and Administration**
- 18.03 Amendments to CBC Chapter 15; Roof Assemblies and Rooftop Structures**
- 18.04 Amendments to CBC Chapter 16; Structural Design**
- 18.05 Amendments to CBC Chapter 17; Structural Tests and Special Inspections**
- 18.06 Amendments to CBC Chapter 18; Soils and Foundations**
- 18.07 Amendments to CBC Chapter 19; Concrete**
- 18.08 Amendments to CBC Chapter 23; Wood**
- 18.09 Amendments to CBC Chapter 25; Gypsum Board and Plaster**
- 18.10 Amendments to CBC Appendix G; Flood Resistant Construction**
- 18.11 Amendments to CRC Chapter 1; Division II; Administration**
- 18.12 Amendments to CRC Chapter 3; Building Planning**
- 18.13 Amendments to CRC Chapter 4; Foundations**
- 18.14 Amendments to CRC Chapter 5; Floors**
- 18.15 Amendments to CRC Chapter 6; Wall Construction**
- 18.16 Amendments to CRC Chapter 8; Roof-Ceiling Construction**
- 18.17 Amendments to CRC Chapter 9; Roof Assemblies**
- 18.18 Amendments to CRC Chapter 10; Chimneys and Fireplaces**

**Chapter 18.01**  
**ADOPTION OF THE CITY BUILDING CODE**

**Sections:**

**18.01.010 Adoption of the City Building Code**

**18.01.010 Adoption of the City Building Code**

There is hereby adopted by reference that certain code known and designated as the California Code of Regulations, Title 24, Parts 1, 2, 2.5, 8,10, and 12 as published by the California Building Standards Commission as further described and including the following:

**2019 California Administrative Code** (California Code of Regulations Title 24, Part 1)

**2019 California Building Code** (California Code of Regulations Title 24, Part 2) based on the 2018 International Building Code® as prepared by the International Code Council, and as amended by the State of California

**2019 California Residential Code** (California Code of Regulations Title 24, Part 2.5) based on the 2018 International Residential Code® as prepared by the International Code Council, and as amended by the State of California

**2019 California Historical Building Code** (California Code of Regulations Title 24, Part 8)

**2019 California Existing Building Code** (California Code of Regulations Title 24, Part 10) based on the 2018 International Existing Building Code® as prepared by the International Code Council, and as amended by the State of California

**2019 California Referenced Standards Code** (California Code of Regulations Title 24, Part 12)

Such code shall include those sections requiring enforcement by the local building department, and as further amended by the City of Santa Clarita with provisions intended to address local climatic, geologic, and topographic conditions, as permitted by state law. Adoption of said code shall include the adoption of Appendix C *Group U-Agricultural Buildings*, Appendix G *Flood Resistant Construction*, Appendix I *Patio Covers*, and Appendix J *Grading*, contained in the 2019 California Building Code and Appendix H *Patio Covers*, contained in the 2019 California Residential Code.

Such code shall become and be the City of Santa Clarita Building Code, regulating the erection, construction, alteration, repair, relocation, demolition, occupancy, use, height, area, and maintenance of all buildings and structures, and certain equipment therein specifically regulated. The provisions of said code shall provide for the issuance of permits and certificates of occupancy, and collection of fees thereof, and providing penalties for violation of such code.

The City of Santa Clarita Building Code shall become effective for all new building permit applications received by the city on or after January 1, 2020.

References in city forms, documents, and regulations to the chapters and sections of former editions of the City of Santa Clarita Building Code shall be construed to apply to the corresponding provisions contained within the current edition of City of Santa Clarita Building Code.

At least one copy of the City of Santa Clarita Building Code shall be maintained and kept available for reference and examination by the public at the city's Permit Center public counter.

**Chapter 18.02**  
**AMENDMENTS TO CHAPTER 1 DIVISION II; SCOPE AND ADMINISTRATION,**  
**OF THE CALIFORNIA BUILDING CODE**

**Sections:**

|                  |   |
|------------------|---|
| <b>18.02.005</b> | <b>Chapter 1 Division II is Amended</b>       |
| <b>18.02.010</b> | <b>Section 101.1 is Amended</b>               |
| <b>18.02.020</b> | <b>Section 103.1 is Amended</b>               |
| <b>18.02.030</b> | <b>Section 105.2 is Amended</b>               |
| <b>18.02.040</b> | <b>Section 105.2.3 is Added</b>               |
| <b>18.02.050</b> | <b>Section 105.3.2 is Amended</b>             |
| <b>18.02.060</b> | <b>Section 105.5 is Amended</b>               |
| <b>18.02.070</b> | <b>Sections 105.5.1 and 105.5.2 are Added</b> |
| <b>18.02.080</b> | <b>Section 105.8 is Added</b>                 |
| <b>18.02.090</b> | <b>Section 107.1 is Amended</b>               |
| <b>18.02.100</b> | <b>Section 109.2 is Amended</b>               |
| <b>18.02.110</b> | <b>Section 109.2.1 is Added</b>               |
| <b>18.02.120</b> | <b>Section 109.4 is Amended</b>               |
| <b>18.02.130</b> | <b>Section 109.6 is Amended</b>               |
| <b>18.02.140</b> | <b>Section 110.3.5 is Amended</b>             |
| <b>18.02.150</b> | <b>Section 110.3.12 is Added</b>              |
| <b>18.02.160</b> | <b>Section 110.7 is Added</b>                 |
| <b>18.02.170</b> | <b>Section 110.8 is Added</b>                 |
| <b>18.02.180</b> | <b>Section 110.9 is Added</b>                 |
| <b>18.02.190</b> | <b>Section 113.3 is Amended</b>               |
| <b>18.02.200</b> | <b>Section 113.4 is Added</b>                 |
| <b>18.02.210</b> | <b>Sections 114.2.1 and 114.2.2 are Added</b> |
| <b>18.02.220</b> | <b>Section 114.4 is Amended</b>               |
| <b>18.02.230</b> | <b>Section 117 is Added</b>                   |
| <b>18.02.240</b> | <b>Section 118 is Added</b>                   |

**18.02.005 Chapter 1 Division II is Amended**

The following sections of Chapter 1 Division II of the California Building Code, as adopted by Chapter 18.01 hereof, are added, deleted or amended as follows:

**18.02.010 Section 101.1 is Amended**

Section 101.1 is amended to read as follows:

**101.1 Title.** These regulations, including all duly adopted local amendments, shall be known as the *Santa Clarita Building Code* and shall be used in conjunction with the provisions of Title 24, California Code of Regulations, mandated by the State of California to be enforced by the local authority having jurisdiction, and shall hereinafter be referred to as “this code.”

**18.02.020 Section 103.1 is Amended**

Section 103.1 is amended to read as follows:

**103.1 Creation of enforcement agency.** There is established within the City of Santa Clarita the Building & Safety division under the administrative and operational control of the City Building Official hereafter referred to as the Building Official.

### 18.02.030 Section 105.2 is Amended

Section 105.2 is amended to read as follows:

**105.2 Work Exempted from Permit.** Exemptions from permit requirements of this code shall not be deemed to grant authorization for any work to be done in any manner in violation of the provisions of this code or any other laws or ordinances of the City of Santa Clarita including such requirements as may be established by any city department or division or the requirements of any other governing agency. Unless otherwise exempted, separate plumbing, electrical, and mechanical permits will be required for any such items exempted herein.

Permits shall not be required for the following:

#### **Building:**

1. One-story detached light-framed structures accessory to a Group R-3 or U occupancy used as tool and storage sheds, playhouses, trellis structures, gazebos, arbors, greenhouses and similar uses where the gross floor area does not exceed 120 square feet as measured to the outside walls or support posts and the structure complies with all of the following conditions:
  - a. The floor is not more than 30 inches above the adjoining grade,
  - b. The overall height is not more than 14 feet as measured from adjacent grade,
  - c. The structure is not constructed on a slope steeper than 3:1,
  - d. The structure is not within a flood hazard or floodplain,
  - e. The structure has no permanent heating or air-conditioning,
  - f. The location of the structure is approved by the city's Planning Division.

Note: Storage or tool sheds over 120 square feet but not exceeding 250 square feet in area that meet the above conditions may be constructed under a 'foundation only' permit. Such permit may include the installation of one 20 Amp branch circuit, (1) light fixture and one (1) 110/115 V. GFCI outlet.

2. Where allowed by the city's Planning Division, chain link or wire fences not over 12 feet in height, wood, vinyl, or open wrought iron fences not over 6 feet in height, and block walls or pilasters not over 42 inches in height where not constructed within a flood hazard or floodplain.
3. Sidewalks and driveways which are not more than 30 inches above adjacent grade and not over any basement or story below, and are not part of an accessible route as required per Chapter 11A or 11B of this code.
4. Decks or platforms accessory to a Group R-3 or U occupancy that are not more than 30 inches above adjacent grade or constructed over a slope or in a flood hazard or floodplain.
5. Exterior hardscape features such as patios, seating walls, walkways, stepped walks or stairs integrated in a slope, koi ponds, fountains or similar water features not over 18 inches in depth, raised planters and similar hardscape features that are accessory to a Group R-3 or U occupancy.
6. Canopies, awnings, or open trellises that do not extend more than 36 inches from the exterior wall of a building or, if attached to a Group R, Division 3, or Group U occupancy, do not extend more than 54 inches and are not within 3 feet of the property line.
7. Retaining walls that are not over 4 feet in height measured from the bottom of the footing to the top of the wall, or where supporting a slope or surcharge, not more than 30 inches in height measured from bottom of footing to the top of the wall. For 'dry stacked' interlocking retaining wall systems such as 'keystone walls' the maximum exempt height is 36 inches above the lowest adjacent grade or 18 inches where supporting a slope or surcharge. This exemption does not apply to retaining walls constructed on a slope steeper than 3:1, located in a floodplain, or impounding Class I, II or IIIA liquids.
8. Fixed or moveable cases, racks, shelving, and partitions not exceeding 6 feet in height. The installation of such elements shall not reduce aisle widths, clearances or means of egress to less than that required by this code.
9. The installation of decorative moldings, trim, window treatments, wall coverings, painting,

papering, tiling, carpeting, hardwood or tile flooring, counters or countertops, tub or shower surrounds and similar interior finish work. Notwithstanding, all such materials and work shall comply with applicable provisions of Chapter 8 of this code for allowable materials, combustibility and fire performance.

10. Garage and closet organizers, cabinets, or shelving not exceeding 8 feet in height within a Group R-3 or U occupancy.
11. Drywall within Group U occupancies not required to be part of a fire rated assembly.
12. The installation of replacement window units where installed within existing frames and where no stucco or siding is removed, provided the following conditions are met:
  - a. The net opening area of the existing window(s) is not reduced to less than that required by this code for light and ventilation
  - b. Any required egress (emergency escape) window is replaced with an egress (emergency escape) window complying with this code.
  - c. The provisions of this code for safety glazing are met.
13. Satellite dishes not exceeding 30 inches in diameter where attached to a structure, or 36 inches in diameter where ground mounted and not exceeding 15 feet in height.
14. Radio or television antennae towers where ground mounted and not exceeding 30 feet in height.
15. Light standards which do not exceed 20 feet in height (electrical permits are required).
16. Flagpoles not exceeding 20 feet in height where not attached to or erected on any building or structure.
17. Prefabricated swimming pools or spas accessory to a Group R-3 occupancy provided that:
  - a. The capacity does not exceed 5,000 gallons
  - b. The pool or spa is not constructed on a slope greater than 3:1
  - c. The lowest point of the bottom of the pool or spa is not more than 24 inches below adjacent grade
  - d. The pool or spa is provided with a safety barrier as required in the California Health & Safety Code

An electrical permit is required for any permanently connected pumps or motors.

18. Removal and replacement of the plaster finish of a swimming pool or spa accessory to a Group R-3 occupancy provided that:
  - a. No mechanical, electrical, or plumbing elements are being added, altered, or removed.
  - b. The swimming pool or spa is equipped with at least two of the drowning prevention safety features listed in Health and Safety Code section 115922.
  - c. The pool or spa is equipped with anti-entrapment grates as specified in Health and Safety Code section 115928.5.
19. Structures or equipment accessory to a Group R occupancy which are intended solely for play or amusement, and which are clearly identifiable as such. These structures may include, but are not limited to: swings, slides, climbing structures and similar playground equipment, skateboard or bike ramps, pool slides whether built-in or free standing, basketball standards, tennis or sports courts (not including fencing or lighting), and similar structures. Notwithstanding, such structures must comply with all applicable zoning standards for use and location. Where a permanently constructed pool slide or other landscape feature also serves as part of a retaining wall, such portions of the construction that act as a retaining wall require a permit unless specifically exempted here in. An electrical permit is required for any permanently connected lighting or other electrical equipment.
20. Tree houses provided that:
  - a. The floor area does not exceed 64 square feet;
  - b. The ceiling height does not exceed 6 feet;
  - c. The tree house is not constructed in an oak tree.
  - d. The tree house does not have mechanical, electrical, or plumbing elements.
21. Temporary sheds, construction trailers, and other structures incidental to work authorized by a

- valid grading or building permit. Electrical and plumbing permits are required when there are any such connections associated with the temporary shed or construction trailer. Any such structure shall be removed upon completion of the work covered by the permit or expiration of the permit.
22. Tents, inflatable structures, and similar canopy structures, where used in conjunction with a special event, that are open on at least three sides and do not exceed 500 square feet in projected area, or where enclosed on two or more sides, that do not exceed 300 square feet in enclosed area. Notwithstanding, all such structures shall be adequately anchored to resist local wind forces.
  23. Temporary stages or platforms that do not exceed 30 inches in height that are used in conjunction with a special event.
  24. Shade cloth structures constructed solely for nursery or agricultural purposes, not including service systems within such structures.
  25. Temporary motion picture, television, and theater stage sets and scenery.
  26. Gantry cranes and similar equipment.
  27. Prefabricated water tanks supported directly on grade where the capacity does not exceed 5,000 gallons and the ratio of height to the diameter or width does not exceed one and one-half to one (1½ :1).
  28. The following work when conducted in association with an operating oil field:
    - a. Oil derricks;
    - b. Installation and relocation of process vessels and tanks;
    - c. Construction, installation and relocation of process piping and pipe supports;
    - d. Construction, installation and relocation of ladders, stairs, and catwalks;
    - e. Installation of foundations for process vessels, pipe supports, generators, tanks, pumps, and uninhabited buildings located more than 20 feet from any property line;
    - f. Construction, installation, and relocation of uninhabited buildings;
    - g. Road maintenance;
    - h. Grading of new and existing well pads, provided the grading does not affect an adjoining property;
    - i. Grading and construction for erosion control, provided it does not affect an adjoining property;
    - j. Debris basin maintenance;(Note: The waiver of a building permit shall not be deemed as a waiver from the oil field operator from obtaining the required clearances from other public agencies.)

**Electrical:**

*Note: refer to the 2019 California Electrical Code with local amendments for additional exemptions*

1. Low-voltage wiring for security systems, telephone or other communication systems, door bells, intercom or sound systems, television cable, and similar installations within a Group R-3 or U occupancy.
2. Electrical equipment used for commercial radio and television transmitting stations, excluding any equipment or wiring for the power supply to any such station.

**Mechanical**

*Note: refer to the 2019 California Mechanical Code with local amendments for additional exemptions*

1. Portable equipment including heating appliances, ventilation equipment, air-conditioning or evaporative cooling units.
2. Self-contained refrigeration systems containing 10 pounds or less of refrigerant and actuated by motors of 1 horsepower or less.

**18.02.040 Section 105.2.3 is Added**

Section 105.2.3 is added to read as follows:

**105.2.3 Repairs and Maintenance.** Application or notice to the Building Official is not required for ordinary maintenance or repairs to structures. In no case shall the repair or maintenance work create an unsafe condition or violate any provision of this code or any other applicable regulation. Such repairs shall not include the cutting away of any wall, partition or portion thereof, the removal or cutting of any structural beam, brace, or load-bearing support, or the removal or change of any required means of egress, or rearrangement of parts of a structure affecting the egress requirements. Ordinary repairs shall not include addition to, alteration of, replacement or relocation of any standpipe, water supply, sewer, drainage, drain leader, gas, soil, waste, vent, or similar piping, electric wiring, mechanical or other work affecting public health or general safety.

Permits shall not be required for the following repair or maintenance work:

1. General building maintenance.
2. Painting, papering, carpeting and similar work.
3. Repair of minor portions of a building or structure damaged by dry-rot, termites, or deterioration provided the elements being replaced do not reduce the integrity of the building or structure.
4. Repairs to a roof on a building or structure not exceeding 10 percent of the total roof area or 200 square feet, whichever is less, provided such exempt limits are not exceeded within any one-year period of time.
5. Drywall repairs not exceeding 200 square feet when not part of a fire rated assembly.
6. Replacement of panes of glass within existing frames provided the provisions of this code for safety glazing are met. Note: refer to exemption 12 under Section 105.2 ‘Work Exempted from Permit; Building’, herein, for additional requirements that may apply.
7. Replacement of any component part of mechanical or electrical equipment provided it does not alter approval of such equipment or make such equipment unsafe.
8. Replacement of any faucet, sink, water closet, shower head or similar plumbing fixture with a fixture of like type. Notwithstanding, the replacement of such fixtures shall comply with applicable provisions of the California Plumbing Code and California Green Building Standards Code for water-conserving fixtures.
9. Replacement of any kitchen appliance, non-commercial hood, exhaust or ceiling fan, lighting fixture, lamp or bulb, or similar item with a fixture, appliance, or other item of like type.
10. The clearing of stoppages or the repairing of leaks in drains, water, soil, waste or vent pipe, provided, however, that if any concealed trap, drainpipe, water, soil, waste or vent pipe or valve becomes necessary to remove and replace the same with new material, such work shall be considered as new work and a permit shall be obtained and inspection made as provided in this code.

**18.02.050 Section 105.3.2 is Amended**

Section 105.3.2 is amended to read as follows:

**105.3.2 Time limitation of application.** An application for which no permit is issued within twelve months following the date of application shall expire by limitation, and plans and other data submitted for review may thereafter be returned to the applicant or destroyed by the Building Official. The Building Official is authorized to grant one or more extensions, each for a period not to exceed 180 days, upon request by the applicant under all of the following conditions:

1. The applicant submits a written request for such extension showing justifiable cause;
2. An administrative fee as established must be paid at the time the extension is granted;
3. Where there have been changes to governing codes under which the plans were originally submitted, the plans shall be revised to reflect any such changes as a condition of the extension. Additional plan review fees will apply in such cases.



#### **18.02.060 Section 105.5 is Amended**

Section 105.5 is amended to read as follows:

**105.5 Expiration.** Every permit issued shall become invalid unless the work on the site authorized by such permit is commenced within twelve months after its issuance as evidenced by a valid inspection of work by the building department. In such cases where the work authorized on the site by such permit has commenced and is then suspended or abandoned for a period of 180 days after the time the work is commenced the permit shall become inactive. The Building Official is authorized to grant one or more extensions for periods of time not to exceed 180 days each, or to reactivate a permit as provided for in section 105.5.1 and 105.5.2.

#### **18.02.070 Sections 105.5.1 and 105.5.2 are Added**

Sections 105.5.1 and 105.5.2 are added to read as follows:

**105.5.1 Reactivation of an Expired Permit.** The Building Official may approve the reactivation of a permit that has become invalid (either expired or inactive), upon written request by the permittee, under the following conditions:

1. The suspension or abandonment of work has not exceeded two years;
2. The permittee demonstrates justifiable cause for the extension;
3. Where there have been changes to the governing codes under which the permit was originally issued, the Building Official may require any work that has not been installed or completed to meet the provisions of the most current governing codes as a condition of reactivation.

**105.5.2 Fees.** In order to renew action on a permit after it has become invalid, the permittee shall pay a fee as determined by the Building Official not to exceed 50 percent of the original permit fee. Any permit extensions subsequent to an initial extension require the payment of an administrative fee as determined.

#### **18.02.080 Section 105.8 is Added**

Section 105.8 is added to read as follows:

**105.8 Combined Building Permits.** A combination permit may be issued for a single project when it is determined that the same contractor is licensed so as to perform all of the proposed work associated with the project and it is reasonable to combine the permits into a single permit.

The following permits may be combined:

1. A combined building permit may be issued for new one-family or two-family dwellings including additions or alterations thereto. Such permits will include all building, electrical, plumbing, heating, ventilating and air-conditioning work but will not include fire sprinkler installations, sewer connections in the public right-of-way, or grading work requiring a permit as specified in the Unified Development Code.
2. A combined permit may be issued for multi-family residential or non-residential construction projects under similar conditions as listed under number one (1) above when prior approval has been granted by the Building Official.
3. A combined building permit may be issued for a swimming pool and shall include excavation and finish grading for construction of the pool and related landscaping, construction of the pool structure, decking, pool equipment enclosure walls, and all such plumbing and electrical work as required for the pool.
4. A combined permit may be issued for a commercial sign and shall include all structural and electrical work required to install the sign.

Combined permits shall not be issued for separate work which is entirely unrelated and under separate trades such as building and electrical.

The combined building permit shall be subject to the requirements of this code, the Electrical Code, the Plumbing Code, the Mechanical Code, the Energy Code and the Green Building Standards Code. The fee for the combined building permit shall be as provided for in Section 109 herein including amendments.

**18.02.090 Section 107.1 is Amended**

Section 107.1 is amended to read as follows:

**107.1 General.** Submittal documents consisting of construction documents, statement of special inspections, geotechnical report and other data shall be submitted with each permit application. Submittal documents may be submitted in electronic format as determined by the Building Official. The construction documents shall be prepared by a registered design professional as outlined in the California *Business and Professions Code* or as determined by the Building Official. Where special conditions exist, the Building Official is authorized to require the construction documents to be prepared by a registered design professional.

**Exception:** (no change)

**18.02.100 Section 109.2 is Amended**

Section 109.2 is amended to read as follows:

**109.2 Schedule of permit fees.** On buildings, structures, alterations, additions, electrical, gas, mechanical and plumbing systems, or any other work requiring a permit, a fee for each permit shall be paid as established by the City Council. Where a combined permit is issued, the permit fee shall include the combined fees for applicable building, electrical, mechanical, plumbing, and sewer work.

**18.02.110 Section 109.2.1 is Added**

Section 109.2.1 is added to read as follows:

**109.2.1 Plans Examination Fees.** When submittal documents are required by Section 107.1 a plan review fee shall be paid in full at the time of submittal of the construction documents to the building department. Said fee shall be as established by the City Council. When submittal documents are incomplete or changed by the applicant so as to require additional plan review or when the project involves deferred submittal items as defined in Section 107.3.4.1, an additional plan review fee shall be charged for such additional time as may be required to review all such additional work.

**18.02.120 Section 109.4 is Amended**

Section 109.4 is amended to read as follows:

**109.4 Work commencing before permit issuance.** Any person who commences any work on a building, structure, electrical, gas, mechanical, or plumbing system for which a permit is required by this code before obtaining the necessary permits shall be subject to an investigation fee whether or not a permit is then or subsequently issued. The investigation fee shall be equal to twice the amount of the permit fee. Payment of such fee shall not exempt any person from compliance with all other provisions of this code nor from any other penalty prescribed by law.

**18.02.130 Section 109.6 is Amended**

Section 109.6 is amended to read as follows:

**109.6 Refunds.** The Building Official may authorize refunding of any fee paid hereunder which was erroneously paid or collected.

The Building Official may authorize refunding of not more than 80 percent of the permit fee paid, excluding issuance fees or plan review fees, when no work has been done under a permit issued in accordance with this code and the applicant has submitted a written request to cancel said permit along with the original signed permit, inspection record card, and construction placard.

The Building Official may authorize refunding of not more than 80 percent of the plans examination fee paid, excluding any application fee, when an application for a permit for which a plan review fee has been paid is withdrawn or canceled prior to commencing any plan review.

The Building Official shall not authorize refunding of any fee paid except on written application filed by the original applicant or permittee not later than 90 days after the date the permit or application for permit has expired, become inactive, been cancelled, or passed a final inspection.

**18.02.140 Section 110.3.5 is Amended**

Section 110.3.5 is amended to delete the exception allowed under this section which excludes the need for an inspection of gypsum board that is not part of a fire-resistance-rated assembly or a shear assembly.

**18.02.150 Section 110.3.12 is Added**

Section 110.3.12 is added to read as follows:

**110.3.12 Reinspections.** A reinspection fee may be assessed for each inspection or reinspection under any of the following conditions:

1. When such portion of work for which inspection is called is not complete and ready.
2. When corrections previously called for by the inspector have not been made.
3. When the approved plans are not readily available to the inspector at the time of the requested inspection.
4. When access to the jobsite is not available at the time the inspection was scheduled.
5. When there is a deviation from the approved plans related to the work to be inspected and such deviation was not previously reviewed and approved by Building & Safety staff.

In instances where a reinspection fee has been assessed, no additional inspection of the work will be performed until the required fee has been paid.

**18.02.160 Section 110.7 is Added**

Section 110.7 is added to read as follows:

**110.7 Construction Placard and Inspection Record Card.** Work requiring a building permit shall not be commenced until the permit holder or the permit holder's agent have posted in a conspicuous location at the construction site, a construction placard provided by the Building Official at the time of permit issuance. Said placard shall not be removed until final approval of the work by the building department. The inspection record card shall also be made available so as to allow the Building Official or his designated representative to conveniently make the required entries thereon regarding inspection of the work.

The Inspection Record Card shall serve as temporary approval to occupy and/or use the described project for up to ten (10) working days following the Final Approval date, when signed with a Final Approval by the Building Official or his designated representative.

**18.02.170 Section 110.8 is Added**

Section 110.8 is added to read as follows:

**110.8 Inspections during declared emergencies.** The Building Official may authorize the performance of inspections required under this section to be performed by registered design professionals or by registered deputy inspectors, for repair work during a declared emergency. The persons performing the inspections shall submit a report, to the satisfaction of the Building Official, demonstrating that the work they inspected conformed to the requirements of all applicable codes. The report will be similar to those required by Section 1704.2.4 of this code.

**18.02.180 Section 110.9 is Added**

Section 110.9 is added to read as follows:

**110.9 Special Inspector registration.** Any person who acts in the capacity of a Special Inspector as defined in Chapter 2 of this code for any project within the City of Santa Clarita requiring special inspections as outlined in Chapter 17 must be registered with the City of Santa Clarita to act in such capacity. In order to be registered, a person must pay a registration fee as established by the city Council and demonstrate to the satisfaction of the Building Official that he or she is qualified to perform those types of special inspections for which he or she is registered. Upon registration, a registration card will be issued to the individual by the Building Official. Registration may be revoked for due cause as determined by the Building Official.

**18.02.190 Section 113.3 is Amended**

Section 113.3 is amended to read as follows:

**113.3 Qualifications.** The Board of Appeals shall consist of those persons currently serving on the Planning Commission as appointed by the City Council.

**18.02.200 Section 113.4 is Added**

Section 113.4 is added to read as follows:

**113.4 Filing of Appeals.** All appeals shall be made in writing and shall state specifically the order, decision, or determination made by the Building Official which is being appealed and wherein the Building Official erred in making the order, decision, or determination. The appeal shall be accompanied with a fee as established by the City Council. If, after reviewing the information submitted, the Building Official determines that the appeal does not merit a change in his order, decision, or determination, then the Building Official shall schedule a hearing by the Board of Appeals and the appellant shall be notified of the date and time of the hearing.

**18.02.210 Sections 114.2.1 and 114.2.2 are Added**

Sections 114.2.1 and 114.2.2 are added to read as follows:

**114.2.1 Recordation of Notice of Violation.** The Building Official may record a notice with the Los Angeles County Registrar-Recorder that a property, building or structure, or any part thereof, is in violation of any provision of this code provided the provisions of this section are followed. The provisions of this section are cumulative with other provisions of this code and any other enforcement actions permitted by this code. A notice of violation may be placed upon the title of a property when violation of the building codes have been verified and documented to exist on the site.

The following procedures are established for recordation of Notice of Violation:

- a. If (1) the Building Official determines that any property, building or structure, or any part thereof is in violation of any provision of this code; and if (2) the Building Official gives written notice as specified below of said violation; and if (3) within 45 days of said notice, the property,

buildings, or structures thereon are not brought into compliance with this code, then the Building Official may, in his sole discretion, at any time thereafter record with the Los Angeles County Registrar-Recorder a notice that the property and/or any building or structure located thereon is in violation of this code.

b. Notice shall be provided in writing in accordance with the following:

1. The notice shall be mailed registered, certified or first-class mail, or may be posted at the site if the site is occupied;
2. The notice shall be addressed to the owner as indicated on the latest county roll;
3. The notice shall specify what violations are being investigated or have been observed or verified;
4. The notice shall indicate what mitigation action is required by the property owner and the time frame in which to commence and complete such mitigation;
5. The notice shall indicate that a notice of violation may be recorded with the Los Angeles County Registrar-Recorder by the Building Official should said violation(s) not be mitigated within 45 days of the date of the notice.

**114.2.2 Termination of Notice of Violation.** When the property owner has demonstrated to the Building Official that violations of the building code no longer exist, and all fees to cover the cost of the investigation of the violations have been paid to the city, as established by the City Council, the Building Official shall terminate the notice of violation upon the written request of the property owner.

#### **18.02.220 Section 114.4 is Amended**

Section 114.4 is amended to read as follows:

**114.4 Violation penalties.** Any person who violates a provision of this code or fails to comply with any of the requirements thereof or who erects, constructs, alters, or repairs a building or structure in violation of the approved construction documents or directive of the Building Official, or of a permit or certificate issued under the provisions of this code, is guilty of a misdemeanor punishable by a fine not exceeding \$1,000 or by imprisonment not exceeding six months, or by both such fine and imprisonment (see Section 17995 of the California Health and Safety Code). Such person shall be guilty of a separate offense for each and every day or portion thereof during which any violation of any of the provisions of this code is committed, continued, or permitted to remain.

Further, violators of this code may be subject to administrative citation and general penalties as provided for in Title 23 of the Santa Clarita Municipal Code.

#### **18.02.230 Section 117 is Added**

Section 117 is added to read as follows:

##### **Section 117 Prohibited Uses of Building Sites**

**117.1 Flood and Debris Hazard Sites.** Buildings, other structures or appurtenances (including but not limited to walls and fences of any height) and fill are not permitted in an area determined by the city to be subject to flood hazard by reason of inundation, overflow, other special flood and debris hazards or erosion except as discussed in this section.

**117.2 Geologic Hazard Sites.** Any site or property determined or suspected to have a geologically hazardous condition or pose a potential threat to nearby properties shall be subject to the provisions of this section.

**117.2.1** No building permit shall be issued when the Building Official finds that property outside the site of the proposed work could be damaged by activation or acceleration of a geologically hazardous condition, and such activation or acceleration could be attributed to the proposed work

for which the permit is requested. For the purpose of this section, geologically hazardous condition does not include surface displacement due to earthquake faults.

**117.2.2** Work requiring a building permit by this code is not permitted in an area determined by the Building Official to be subject to hazard from landslide, settlement or slippage. These hazards include those from loose debris, slopewash, and the potential for mudflows from natural slopes or graded slopes. For the purpose of this section, landslide, settlement or slippage does not include surface displacement due to the earthquake faults.

**117.2.3** Subject to the conditions of section 117.2.1 permits may be issued in the following cases:

- a. When the applicant has submitted a geological and/or engineering report or reports which show that the hazard will be eliminated prior to the use of occupancy of the land or structures by modification of topography, reduction of subsurface water, buttressing, a combination of these methods, or by other means.
- b. When the applicant has submitted a geological and/or engineering report or reports which contain sufficient data to show that the site appears to be in no danger for the intended use.
- c. When the applicant has submitted a geological report which indicates that the site appears to be geologically safe for the proposed use but is located in an area subject to a hazard of a geological nature. However, before a permit is issued, the owner first shall record in the Department of Registrar-Recorder the findings of such report or reports, together with an agreement relieving the city and all officers and employees thereof of any liability for any damage or loss which may result from the issuance of such permit. This agreement shall provide that it is binding on all successors in interest of the owner and shall continue in effect until the Building Official records in the Department of Registrar-Recorder a statement that he finds such hazard no longer exists.
- d. When the work involves the alteration or minor repair of existing structures and the cost of such alteration or repair does not exceed 25 percent of the value of the existing structure, such value to be based on assumed continuation of the established legal use. Before a permit is issued, the owner shall record in the office of the Department of Registrar-Recorder (1) a statement that he or she is aware that the records of the Building Official indicate that the property is subject to a physical hazard of a geological nature and (2) an agreement relieving the city and all officers and employees thereof of any liability for any damage or loss which may result from issuance of such a permit. This agreement shall provide that it is binding on all successors in interest of the owner and shall continue in effect until the Building Official records in the office of the Department of Registrar-Recorder a statement that he finds such hazard no longer exists. The repair work shall consist of restoring the original construction. Provision may be made for adjustment of the floor in anticipation of future settlement. For the purposes of this section "alteration" does not include an addition or additions.
- e. When the work involves an addition or additions to an existing structure but is not a change in use or occupancy and such work does not increase the area of the structure by more than 25 percent of the area of the structure. Before a permit is issued, the applicant shall submit a geological and/or engineering report or reports complying with the provisions of Section 117.6 which contains a finding that the proposed increased use of the site will not be geologically unsafe, and the owner shall record in the office of the Department of Registrar-Recorder (1) the finding of such report or reports and (2) an agreement relieving the city and all officers and employees thereof of any liability for any damage or loss which may result from the issuance of such a permit. This agreement shall provide that it is binding on all successors in interest of the owner and shall continue in effect until the Building Official records in the office of the Department of Registrar-Recorder a statement that he finds a hazard no longer exists.

- f. When the work involves a one-story, light-frame accessory structure not intended or used for human occupancy and not exceeding 400 square feet in area nor greater than 12 feet in height.
- g. When the work involves the repair of single-family residences and accessory buildings where the cost of such repair exceeds 25 percent of the value of the existing building or involves the replacement of such structures where the loss to be replaced was due to causes other than landslide, settlement or slippage. Before a permit is issued the owner shall:
  - 1) Record in the office of the Department of Registrar-Recorder (1) a statement that he or she is the owner and that he or she is aware that the records of the Building Official indicate that the property is subject to a physical hazard of a geological nature and (2) an agreement relieving the city and all officers and employees thereof of any liability for any damage or loss which may result from issuance of such a permit. This agreement shall provide that it is binding on all successors in interest of the owner and shall continue in effect until the Building Official records in the office of the Department of Registrar-Recorder a statement that he finds such hazard no longer exists.
  - 2) Submit calculations and plans for the proposed reconstruction prepared by a registered civil engineer and designed to minimize damage while accommodating the amount of vertical and horizontal displacements which he or she determines are probable or which have occurred since the original structure was built, whichever is the greater.
- h. Notwithstanding any other provisions of this section, the Building Official may, at his discretion, deny a permit for any building, structure or grading subject to a hazard of a geological nature which cannot be mitigated and may endanger the health or safety of the occupants, adjoining property, or the public.

**117.3 Fills Containing Decomposable Material.** Permits shall not be issued for buildings or structures regulated by this code within 1,000 feet of fills containing rubbish or other decomposable material unless the fill is isolated by approved natural or man-made protective systems or unless designed according to the recommendation contained in a report prepared by a licensed civil engineer. Such report shall contain a description of the investigation, study and recommendation to minimize the possible intrusion, and to prevent the accumulation of explosive concentrations of decomposition gases within or under enclosed portions of such building or structure. At the time of the final inspection, the civil engineer shall furnish a signed statement attesting that the building or structure has been constructed in accordance with his or her recommendations as to decomposition gases required herein.

**117.4 Conditional Use.** Work required by this section as a condition for the use of the site shall be performed prior to the connection of the utilities or occupancy of the building.

**117.5 Methane Gas Hazard Sites.** Permits shall not be issued for buildings or structures regulated by this code on, adjacent to, or within 200 feet of active, abandoned or idle oil or gas well(s) unless designed according to recommendations contained in a report prepared by a licensed civil engineer and approved by the Building Official. As used in this section, "well" shall mean any well as defined by Section 3008, subdivisions (a) and (b) of the California Public Resources Code.

**117.6 Geology and Engineering Reports.** The Building Official may require an engineering geology or geotechnical engineering report, or both, where in his opinion such reports are essential for the evaluation of the safety of the site. The engineering geology or geotechnical engineering report or both shall contain a finding regarding the safety of the building site for the proposed structure against hazard from landslide, settlement, or slippage and a finding regarding the effect that the proposed building or grading construction will have on the geologic stability of the property in question and properties immediately adjacent. Any engineering geology report shall be prepared by a certified

engineering geologist licensed by the State of California. Any geotechnical engineering report shall be prepared by a civil engineer qualified to perform this work, such as a geotechnical engineer experienced in soil mechanics. When both an engineering geology and geotechnical engineering report are required for the evaluation of the safety of a building site, the two reports shall be coordinated before submission to the Building Official.

### **117.7 Earthquake Faults.**

- 1. General.** The construction of a building or structure near a known active earthquake fault and regulated by this code shall be permitted as set forth in this section.
- 2. Scope.** The provisions of this section shall apply only to permits for buildings or structures on individual lots or parcels and are not intended to be supplementary to geologic investigations required to qualify divisions of land as set forth in the Uniform Development Code of the City of Santa Clarita.
- 3. Definition.** For the purpose of this section, a "geologist" shall be a registered geologist, licensed by the California State Board of Registration for Geologists and Geophysicists to practice geology in California.
- 4. Known Active Earthquake Faults.** For the purpose of this section, known active earthquake faults are those faults which have had displacement within Holocene time (approximately the last 11,000 years) as defined in the most current issue of Special Publication 42 of the California Division of Mines and Geology.
- 5. Earthquake Fault Maps.** Special studies zone maps within the City of Santa Clarita prepared under Sections 2622 and 2623 of the California Resources Code which show traces of earthquake faults are declared to be, on the date of official issues, a part of this code. Special studies zones maps revised under the above sections of the California Resources Code shall, on the date of their official issue, supersede previously issued maps. Copies of each of the above maps shall be available for examination by the public at the city. The city shall maintain maps available to the public showing the location of known active earthquake faults. In the absence of additional information, the location of known active earthquake faults shall be as shown on special studies zones maps.
- 6. Construction Limitations.** No building or structure shall be constructed over or upon the trace of a known active earthquake fault in the following cases:
  - a. When the proposed building is within 50 feet of that line designated as the location of a known active earthquake fault on the aforementioned maps.
  - b. When the proposed building is within 50 feet of the most probable ground location of the trace of a known active earthquake fault shown on the aforementioned maps.

In cases when a geologist has not made such a determination, the city may require the excavation of a trench, as a subsurface exploration for the purpose of determining the absence of a known active earthquake fault. Such a trench will be required if a lack of distinguishable fault features in the vicinity prevents the city from determining by a site examination, review of available aerial photographs, or by other means that the fault trace does not underlie the proposed building. The trench shall be approximately perpendicular to the most probable direction of the fault trace, at least 18 inches wide, and at least five feet in depth measured from natural grade, or to a depth satisfactory to the city.

The trench must be accessible for mapping and inspection by the city, when requested, and meet the requirements of Title 8 of the California Code of Regulations, Construction Safety Orders. The trench need not extend further than the full width of the proposed structure plus five feet beyond the traversed exterior walls. A known active earthquake fault shall be presumed nonexistent if an exposure is not found in the walls or floor of the trench. The city may require a more extensive investigation by a geologist as evidence to the absence of a known active earthquake fault prior to the issuance of a building permit.

**Exception:** The provisions of this section do not apply to:



1. One-story, light-frame buildings classified as R-3 and U occupancies and not exceeding 1,000 square feet in area or 12 feet in height.
  2. Alterations or repairs to an existing building provided that the aggregate value of such work within any 12 month period does not exceed 50 percent of the value of the existing building.
  3. Swimming pools, retaining walls, fences and minor work of a similar nature.
7. **Special Studies Zones.** Work within the special studies zones established under Sections 2622 and 2623 of the California Public Resources Code shall comply with State laws, policies, criteria, rules and regulations applicable to such work. Fees established by Chapter 7.5 of Division 2 of the California Public Resources Code shall be collected and disbursed as required by State law. In addition to the State regulations, the provisions of this section shall apply when geologic investigations, mapping, aerial photographs, other acceptable data or Special Studies Zones Maps show the location of a known active earthquake fault as described in this section.

**18.02.240 Section 118 is Added**

Section 118 is added to read as follows:

**Section 118 Fire Hazard Zones ("Very High Fire Hazard Severity Zones")**

**118.1 General.** For the purpose of this code, Fire Hazard Zones are those areas in the City of Santa Clarita that have been designated as Very High Fire Hazard Severity Zones (VHFHSZ) by the Director of the California Department of Forestry and Fire Prevention and as shown on a map titled "City of Santa Clarita Fire Zone Map" retained on file by the city's Building & Safety Division. Such map is declared to be, on the date of issue, a part of this code. Should revisions be made to the map at the recommendation of the Director of the California Department of Forestry and Fire Prevention, the revised map, at the date of issue, shall supersede the previously issued map.

**118.2 Scope.** The provisions of this section shall apply to new buildings or structures on individual lots or parcels that are located in a Fire Hazard Zone as determined from the City of Santa Clarita Fire Zone Map for which an application for a permit is submitted.

**118.3 Construction requirements for buildings or structures in the Fire Hazard Zone**

**118.3.1 General.** Any building or structure hereafter erected, constructed, altered, added onto, or moved within or into a Fire Hazard Zone shall comply with all applicable provisions of Chapter 7A or Section R337 of this code.

**118.3.2 Roof covering repair or replacement.** Roof covering on an existing building or structure that is being repaired or replaced shall comply with Section 1511 of this code.

**118.3.3 Exterior wall covering of existing buildings.** Where the exterior wall covering of an existing building or structure is being repaired or replaced and the cumulative area being repaired or replaced is greater than 50 percent of the total existing wall area, both the new and existing wall covering shall comply with the provisions of Section 707A or Section R337.7 of this code in their entirety. The provisions of this section shall be cumulative over any one-year period.

**118.3.4 Exterior windows and doors of existing buildings.** Where exterior windows and/or doors of an existing building are being replaced with new windows and/or doors, and where the number of windows and/or doors being replaced is greater than 50 percent of the total number of windows and/or doors on the building, all windows and/or doors on the building shall comply with Section 708A or Section R337.8 of this code. The provisions of this section shall be cumulative over any one-year period.

**Chapter 18.03**  
**AMENDMENTS TO CHAPTER 15; ROOF ASSEMBLIES AND ROOFTOP**  
**STRUCTURES, OF THE CALIFORNIA BUILDING CODE**

**Sections:**

- 18.03.005 Chapter 15 is Amended**
- 18.03.010 Table 1505.1 is Amended**
- 18.03.020 Section 1505.1.3 is Amended**
- 18.03.030 Section 1505.6.1 is Added**
- 18.03.040 Section 1507.3.1 is Amended**
- 18.03.050 Section 1507.8.1 is Amended**
- 18.03.060 Section 1507.9.1 is Amended**
- 18.03.070 Section 1511.3.2 is Added**
- 18.03.080 Section 1511.4 is Amended**
- 18.03.090 Section 1511.7 is Added**

**18.03.005 Chapter 15 is Amended**

The following sections of Chapter 15 of the California Building Code, as adopted by Chapter 18.01 hereof, are added, deleted, or amended as follows:

**18.03.010 Table 1505.1 is Amended**

Table 1505.1 is amended as follows:

**TABLE 1505.1<sup>a</sup>**  
**MINIMUM ROOF COVERING CLASSIFICATION**  
**FOR TYPES OF CONSTRUCTION**

|    |    |     |     |      |      |    |    |    |
|----|----|-----|-----|------|------|----|----|----|
| IA | IB | IIA | IIB | IIIA | IIIB | IV | VA | VB |
| B  | B  | B   | B   | B    | B    | B  | B  | B  |

For SI: 1 foot = 304.8 mm, 1 square foot = 0.0929 m<sup>2</sup>  
a. Unless otherwise required in accordance with Chapter 7A.

**18.03.020 Section 1505.1.3 is Amended**

Section 1505.1.3 is amended to read as follows:

**1505.1.3 Roof coverings within all other areas.** The entire roof covering of every existing structure where more than 50 percent of the total roof area is replaced within any one-year period, the entire roof covering of every new structure, and any roof covering applied in the alteration, repair, or replacement of the roof of every existing structure, shall be a fire-retardant roof covering that is at least Class B.

**18.03.030 Section 1505.6.1 is Added**

Section 1505.6.1 is added to read as follows:

**1505.6.1 City of Santa Clarita Fire Hazard Zone.** Wood shingles and wood shakes are not permitted to be used in any area that is within the City of Santa Clarita’s Fire Hazard Zone (very high fire hazard severity zone) as shown on the city’s Fire Zone Map.

**18.03.040 Section 1507.3.1 is Amended**

Section 1507.3.1 is amended to read as follows:

**1507.3.1 Deck Requirements.** Concrete and clay tile shall be installed over solid structural sheathing.

**18.03.050 Section 1507.8.1 is Amended**

Section 1507.8.1 is amended to read as follows:

**1507.8.1 Deck requirements.** Wood shingles shall be installed over solid structural sheathing.

**18.03.060 Section 1507.9.1 is Amended**

Section 1507.9.1 is amended to read as follows:

**1507.9.1 Deck requirements.** Wood shakes shall be installed over solid structural sheathing.

**18.03.070 Section 1511.3.2 is Added**

Section 1511.3.2 is added to read as follows:

**1511.3.2 Roof replacement over spaced sheathing.** Where spaced sheathing was originally installed as the supporting material, new solid sheathing shall be added prior to the installation of the new roofing material.

**18.03.080 Section 1511.4 is Amended**

Section 1511.4 is amended to read as follows:

**1511.4 Roof recovering.** Where the application of a new roof covering is proposed over wood shingle or shake roofs, the entire existing surface roofing material including all layers of wood shingle or shake shall first be removed.

**18.03.090 Section 1511.7 is Added**

Section 1511.7 is added to read as follows:

**1511.7 Inspections.** An inspection shall be required for all reroofing installations upon removal of all existing layers of roof coverings or, where the existing roof covering is to be recovered, prior to the installation of the new roofing material. Prior to such inspection, any damaged areas of the roof deck or structural framing members shall be repaired or replaced with new material.

**Chapter 18.04**  
**AMENDMENTS TO CHAPTER 16; STRUCTURAL DESIGN, OF THE CALIFORNIA**  
**BUILDING CODE**

**Sections:**

|                  |                                  |
|------------------|----------------------------------|
| <b>18.04.005</b> | <b>Chapter 16 is Amended</b>     |
| <b>18.04.010</b> | <b>Section 1612.3 is Amended</b> |
| <b>18.04.015</b> | <b>Section 1613.3.1 is Added</b> |
| <b>18.04.020</b> | <b>Section 1613.5 is Added</b>   |
| <b>18.04.030</b> | <b>Section 1613.6 is Added</b>   |
| <b>18.04.040</b> | <b>Section 1613.7 is Added</b>   |
| <b>18.04.050</b> | <b>Section 1613.8 is Added</b>   |
| <b>18.04.060</b> | <b>Section 1613.9 is Added</b>   |
| <b>18.04.070</b> | <b>Section 1613.10 is Added</b>  |
| <b>18.04.080</b> | <b>Section 1613.11 is Added</b>  |

**18.04.005 Chapter 16 is Amended**

The following sections of Chapter 16 of the California Building Code, as adopted by Chapter 18.01 hereof, are added, deleted, or amended as follows:

**18.04.010 Section 1612.3 is Amended**

Section 1612.3 is amended to read as follows:

**1612.3 Establishment of flood hazard areas.** There is a map along with supporting data adopted by the City of Santa Clarita that designates areas of special flood hazard as identified by the Federal Emergency Management Agency (FEMA) in an engineering report entitled “The Flood Insurance Study Los Angeles County and Incorporated Areas”, dated September 26, 2008, as amended or revised with the accompanying Flood Insurance Rate Map (FIRM) and Flood Boundary and Floodway Map (FBFM) and related supporting data along with any revisions thereto. The most current amended or revised version of the flood hazard map and supporting data are hereby adopted by reference and declared to be part of this section.

**18.04.015 Section 1613.3.1 is Added**

Section 1613.3.1 is added to read as follows:

**1613.3.1 Ballasted photovoltaic panel systems.** The structural design of ballasted roof-mounted photovoltaic panel systems shall comply with the requirements of Structural Engineers Association of California (SEAOC) PV1-2012 & SEAOC PV2-2017.

**18.04.020 Section 1613.5 is Added**

Section 1613.5 is added to read as follows:

**1613.5 ASCE 7, 12.12.3.** Modify ASCE 7 Equation 12.12-1 of Section 12.12.3 to read as follows:

$$\delta_M = C_d \delta_{max} \quad (\text{Equation 12.2-1})$$

**18.04.030 Section 1613.6 is Added**

Section 1613.6 is added to read as follows:

**1613.6 ASCE 7, 12.2.3.1, Exception 3.** Modify ASCE 7 Section 12.2.3.1 Exception 3 to read as follows:

3. Detached one- and two-family dwellings up to two stories in height of light frame construction.

**18.04.040 Section 1613.7 is Added**

Section 1613.7 is added to read as follows:

**1613.7 ASCE 7, Section 12.11.2.2.3.** Modify ASCE 7, Section 12.11.2.2.3 to read as follows:

**12.11.2.2.3 Wood Diaphragms.** In wood diaphragms, the continuous ties shall be in addition to the diaphragm sheathing. Anchorage shall not be accomplished by use of toe nails or nails subject to withdrawal nor shall wood ledgers or framing be used in cross-grain bending or cross-grain tension. The diaphragm sheathing shall not be considered effective as providing ties or struts required by this section.

Wood diaphragms supporting concrete or masonry walls shall comply with the following:

1. The spacing of continuous ties shall not exceed 40 feet. Added chords of diaphragms may be used to form sub-diaphragms to transmit the anchorage forces to the main continuous crossties.
2. The maximum diaphragm shear used to determine the depth of the sub-diaphragm shall not exceed 75% of the allowable diaphragm shear.

**18.04.050 Section 1613.8 is Added**

Section 1613.8 is added to read as follows:

**1613.8 Seismic Design Provisions for Hillside Buildings.**

**1613.8.1 Purpose.** The purpose of this section is to establish minimum regulations for the design and construction of new buildings and additions to existing buildings when constructing such buildings on or into slopes steeper than one unit vertical in three units horizontal (33.3%). These regulations establish minimum standards for seismic force resistance to reduce the risk of injury or loss of life in the event of earthquakes.

**1613.8.2 Scope.** The provisions of this section shall apply to the design of the lateral-force-resisting system for hillside buildings at and below the base level diaphragm. The design of the lateral-force resisting system above the base level diaphragm shall be in accordance with the provisions for seismic and wind design as required elsewhere in this division.

**Exception:** Non-habitable accessory buildings and decks not supporting or supported from the main building are exempt from these regulations.

**1613.8.3 Definitions.** For the purposes of this section certain terms are defined as follows:

**BASE LEVEL DIAPHRAGM** is the floor at, or closest to, the top of the highest level of the foundation.

**DIAPHRAGM ANCHORS** are assemblies that connect a diaphragm to the adjacent foundation at the uphill diaphragm edge.

**DOWNHILL DIRECTION** is the descending direction of the slope approximately perpendicular to the slope contours.

**FOUNDATION** is concrete or masonry which supports a building, including footings, stem walls, retaining walls, and grade beams.

**FOUNDATION EXTENDING IN THE DOWNHILL DIRECTION** is a foundation running

downhill and approximately perpendicular to the uphill foundation.

HILLSIDE BUILDING is any building or portion thereof constructed on or into a slope steeper than one unit vertical in three units horizontal (33.3%). If only a portion of the building is supported on or into the slope, these regulations apply to the entire building.

PRIMARY ANCHORS are diaphragm anchors designed for and providing a direct connection as described in Sections 1613.8.5 and 1613.8.7.3 between the diaphragm and the uphill foundation.

SECONDARY ANCHORS are diaphragm anchors designed for and providing a redundant diaphragm to foundation connection, as described in Sections 1613.8.6 and 1613.8.7.4.

UPHILL DIAPHRAGM EDGE is the edge of the diaphragm adjacent and closest to the highest ground level at the perimeter of the diaphragm.

UPHILL FOUNDATION is the foundation parallel and closest to the uphill diaphragm edge

#### **1613.8.4 Analysis and Design.**

**1613.8.4.1 General.** Every hillside building within the scope of this section shall be analyzed, designed, and constructed in accordance with the provisions of this division. When the code prescribed wind design produces greater effects, the wind design shall govern, but detailing requirements and limitations prescribed in this and referenced sections shall be followed.

**1613.8.4.2 Base Level Diaphragm-Downhill Direction.** The following provisions shall apply to the seismic analysis and design of the connections for the base level diaphragm in the downhill direction.

**1613.8.4.2.1 Base for Lateral Force Design Defined.** For seismic forces acting in the downhill direction, the base of the building shall be the floor at or closest to the top of the highest level of the foundation.

**1613.8.4.2.2 Base Shear.** In developing the base shear for seismic design, the response modification coefficient (R) shall not exceed 5 for bearing wall and building frame systems. The total base shear shall include the forces tributary to the base level diaphragm including forces from the base level diaphragm.

#### **1613.8.5 Base Shear Resistance-Primary Anchors.**

**1613.8.5.1 General.** The base shear in the downhill direction shall be resisted through primary anchors from diaphragm struts provided in the base level diaphragm to the foundation.

**1613.8.5.2 Location of Primary Anchors.** A primary anchor and diaphragm strut shall be provided in line with each foundation extending in the downhill direction. Primary anchors and diaphragm struts shall also be provided where interior vertical lateral-force-resisting elements occur above and in contact with the base level diaphragm. The spacing of primary anchors and diaphragm struts or collectors shall in no case exceed 30 feet (9144 mm).

**1613.8.5.3 Design of Primary Anchors and Diaphragm Struts.** Primary anchors and diaphragm struts shall be designed in accordance with the requirements of Section 1613.8.8.

**1613.8.5.4 Limitations.** The following lateral-force-resisting elements shall not be designed to resist seismic forces below the base level diaphragm in the downhill direction:

1. Wood structural panel wall sheathing,
2. Cement plaster and lath,
3. Gypsum wallboard, and

#### 4. Tension only braced frames.

Braced frames designed in accordance with the requirements of Section 2205.2.2 may be used to transfer forces from the primary anchors and diaphragm struts to the foundation provided lateral forces do not induce flexural stresses in any member of the frame or in the diaphragm struts. Deflections of frames shall account for the variation in slope of diagonal members when the frame is not rectangular.

### **1613.8.6. Base Shear Resistance-Secondary Anchors.**

**1613.8.6.1 General.** In addition to the primary anchors required by Section 1613.8.5, the base shear in the downhill direction shall be resisted through secondary anchors in the uphill foundation connected to diaphragm struts in the base level diaphragm.

**Exception:** Secondary anchors are not required where foundations extending in the downhill direction spaced at not more than 30 feet (9144 mm) on center extend up to and are directly connected to the base level diaphragm for at least 70% of the diaphragm depth.

**1613.8.6.2 Secondary Anchor Capacity and Spacing.** Secondary anchors at the base level diaphragm shall be designed for a minimum force equal to the base shear, including forces tributary to the base level diaphragm, but not less than 600 pounds per lineal foot (ASD) (8.76 kN/m). The secondary anchors shall be uniformly distributed along the uphill diaphragm edge and shall be spaced a maximum of four feet (1219 mm) on center.

**1613.8.6.3 Design.** Secondary anchors and diaphragm struts shall be designed in accordance with Section 1613.8.8.

**1613.8.7 Diaphragms Below the Base Level-Downhill Direction.** The following provisions shall apply to the lateral analysis and design of the connections for all diaphragms below the base level diaphragm in the downhill direction.

**1613.8.7.1 Diaphragm Defined.** Every floor level below the base level diaphragm shall be designed as a diaphragm.

**1613.8.7.2 Design Force.** Each diaphragm below the base level diaphragm shall be designed for all tributary loads at that level using a minimum seismic force factor not less than the base shear coefficient.

**1613.8.7.3 Design Force Resistance-Primary Anchors.** The design force described in Section 1613.8.7.2 shall be resisted through primary anchors from diaphragm struts provided in each diaphragm to the foundation. Primary anchors shall be provided and designed in accordance with the requirements and limitations of Section 1613.8.5.

#### **1613.8.7.4 Design Force Resistance-Secondary Anchors.**

**1613.8.7.4.1 General.** In addition to the primary anchors required in Section 1613.8.7.3, the design force in the downhill direction shall be resisted through secondary anchors in the uphill foundation connected to diaphragm struts in each diaphragm below the base level.

**Exception:** Secondary anchors are not required where foundations extending in the downhill direction, spaced at not more than 30 feet (9144 mm) on center, extend up to and are directly connected to each diaphragm below the base level for at least 70% of the diaphragm depth.

**1613.8.7.4.2 Secondary Anchor Capacity.** Secondary anchors at each diaphragm below the base level diaphragm shall be designed for a minimum force equal to the design force but not less than 300 pounds per lineal foot (ASD) (4.38 kN/m). The secondary anchors shall be

uniformly distributed along the uphill diaphragm edge and shall be spaced a maximum of four feet (1219 mm) on center.

**1613.8.7.4.3 Design.** Secondary anchors and diaphragm struts shall be designed in accordance with Section 1613.8.8.

**1613.8.8 Primary and Secondary Anchorage and Diaphragm Strut Design.** Primary and secondary anchors and diaphragm struts shall be designed in accordance with the following provisions:

1. **Fasteners.** All bolted fasteners used to develop connections to wood members shall be provided with square plate washers at all bolt heads and nuts. Washers shall be minimum 0.229 inch by 3 inches by 3 inches (5.82 mm by 76 mm by 76 mm) in size. Nuts shall be tightened to finger tight plus one half (1/2) wrench turn prior to covering the framing.
2. **Fastening.** The diaphragm to foundation anchorage shall not be accomplished by the use of toenailing, nails subject to withdrawal, or wood in cross-grain bending or cross-grain tension.
3. **Size of Wood Members.** Wood diaphragm struts collectors, and other wood members connected to primary anchors shall not be less than three-inch (76 mm) nominal width. The effects of eccentricity on wood members shall be evaluated as required per Item 9.
4. **Design.** Primary and secondary anchorage, including diaphragm struts, splices, and collectors shall be designed for 125% of the tributary force.
5. **Allowable Stress Increase.** The one-third allowable stress increase permitted under Section 1605.3.2 shall not be taken when the working (allowable) stress design method is used.
6. **Steel Element of Structural Wall Anchorage System.** The strength design forces for steel elements of the structural wall anchorage system, with the exception of anchor bolts and reinforcing steel, shall be increased by 1.4 times the forces otherwise required.
7. **Primary Anchors.** The load path for primary anchors and diaphragm struts shall be fully developed into the diaphragm and into the foundation. The foundation must be shown to be adequate to resist the concentrated loads from the primary anchors.
8. **Secondary Anchors.** The load path for secondary anchors and diaphragm struts shall be fully developed in the diaphragm but need not be developed beyond the connection to the foundation.
9. **Symmetry.** All lateral force foundation anchorage and diaphragm strut connections shall be symmetrical. Eccentric connections may be permitted when demonstrated by calculation or tests that all components of force have been provided for in the structural analysis or tests.
10. **Wood Ledgers.** Wood ledgers shall not be used to resist cross-grain bending or cross-grain tension.

#### **1613.8.9 Lateral-Force-Resisting Elements Normal to the Downhill Direction.**

**1613.8.9.1 General.** In the direction normal to the downhill direction, lateral-force-resisting elements shall be designed in accordance with the requirements of this section.

**1613.8.9.2 Base Shear.** In developing the base shear for seismic design, the response modification coefficient (R) shall not exceed 5 for bearing wall and building frame systems.

**1613.8.9.3 Vertical Distribution of Seismic Forces.** For seismic forces acting normal to the downhill direction the distribution of seismic forces over the height of the building using Section 12.8.3 of ASCE 7 shall be determined using the height measured from the top of the lowest level of the building foundation.



**1613.8.9.4 Drift Limitations.** The story drift below the base level diaphragm shall not exceed 0.007 times the story height at strength design force level. The total drift from the base level diaphragm to the top of the foundation shall not exceed 3/4 inch (19 mm). Where the story height or the height from the base level diaphragm to the top of the foundation varies because of a stepped footing or story offset, the height shall be measured from the average height of the top of the foundation. The story drift shall not be reduced by the effect of horizontal diaphragm stiffness.

#### **1613.8.9.5 Distribution of Lateral Forces.**

**1613.8.9.5.1 General.** The design lateral force shall be distributed to lateral-force-resisting elements of varying heights in accordance with the stiffness of each individual element.

**1613.8.9.5.2 Wood Structural Panel Sheathed Walls.** The stiffness of a stepped wood structural panel shear wall may be determined by dividing the wall into adjacent rectangular elements, subject to the same top of wall deflection. Deflections of shear walls may be estimated by AF&PA SDPWS. Sheathing and fastening requirements for the stiffest section shall be used for the entire wall. Each section of wall shall be anchored for shear and uplift at each step. The minimum horizontal length of a step shall be 8 feet (2438 mm) and the maximum vertical height of a step shall be 2 feet, 8 inches (813 mm).

**1613.8.9.5.3 Reinforced Concrete or Masonry Shear Walls.** Reinforced concrete or masonry shear walls shall have forces distributed in proportion to the rigidity of each section of the wall.

**1613.8.9.6 Limitations.** The following lateral force-resisting-elements shall not be designed to resist lateral forces below the base level diaphragm in the direction normal to the downhill direction:

1. Cement plaster and lath,
2. Gypsum wallboard, and
3. Tension-only braced frames.

Braced frames designed in accordance with the requirements of Section 2205.2.2 of this code may be designed as lateral-force-resisting elements in the direction normal to the downhill direction, provided lateral forces do not induce flexural stresses in any member of the frame. Deflections of frames shall account for the variation in slope of diagonal members when the frame is not rectangular.

#### **1613.8.10 Specific Design Provisions.**

**1613.8.10.1 Footings and Grade Beams.** All footings and grade beams shall comply with the following:

1. Grade beams shall extend at least 12 inches (305 mm) below the lowest adjacent grade and provide a minimum 24-inch (610 mm) distance horizontally from the bottom outside face of the grade beam to the face of the descending slope.
2. Continuous footings shall be reinforced with at least two No. 4 reinforcing bars at the top and two No. 4 reinforcing bars at the bottom.
3. All main footing and grade beam reinforcement steel shall be bent into the intersecting footing and fully developed around each corner and intersection.
4. All concrete stem walls shall extend from the foundation and reinforced as required for concrete or masonry walls.

**1613.8.10.2 Protection against Decay and Termites.** All wood to earth separations shall comply with the following:

1. Where a footing or grade beam extends across a descending slope, the stem wall, grade beam, or footing shall extend up to a minimum 18 inches (457 mm) above the highest adjacent grade.

**Exception:** At paved garage and doorway entrances to the building, the stem wall need only extend to the finished concrete slab, provided the wood framing is protected with a moisture proof barrier.

2. Wood ledgers supporting a vertical load of more than 100 pounds per lineal foot (ASD) (1.46 kN/m) and located within 48 inches (1219 mm) of adjacent grade are prohibited. Galvanized steel ledgers and anchor bolts, with or without wood nailers, or treated or decay resistant sill plates supported on a concrete or masonry seat, may be used.

**1613.8.10.3 Sill Plates.** All sill plates and anchorage shall comply with the following:

1. All wood framed walls, including nonbearing walls, when resting on a footing, foundation, or grade beam stem wall, shall be supported on wood sill plates bearing on a level surface.

2. Power-driven fasteners shall not be used to anchor sill plates except at interior non-bearing walls not designed as shear walls.

**1613.8.10.4 Column Base Plate Anchorage.** The base of isolated wood posts (not framed into a stud wall) supporting a vertical load of 4,000 pounds (ASD) (17.8 kN) or more and the base plate for a steel column shall comply with the following:

1. When the post or column is supported on a pedestal extending above the top of a footing or grade beam, the pedestal shall be designed and reinforced as required for concrete or masonry columns. The pedestal shall be reinforced with a minimum of four No. 4 bars extending to the bottom of the footing or grade beam. The top of exterior pedestals shall be sloped for positive drainage.

2. The base plate anchor bolts or the embedded portion of the post base, and the vertical reinforcing bars for the pedestal, shall be confined with two No. 4 or three No. 3 ties within the top five inches (127 mm) of the concrete or masonry pedestal. The base plate anchor bolts shall be embedded a minimum of 20 bolt diameters into the concrete or masonry pedestal. The base plate anchor bolts and post bases shall be galvanized and each anchor bolt shall have at least two galvanized nuts above the base plate.

**1613.8.10.5 Steel Beam to Column Supports.** All steel beam to column supports shall be positively braced in each direction. Steel beams shall have stiffener plates installed on each side of the beam web at the column. The stiffener plates shall be welded to each beam flange and the beam web. Each brace connection or structural member shall consist of at least two 5/8 inch (15.9 mm) diameter machine bolts.

#### **18.04.060 Section 1613.9 is Added**

Section 1613.9 is added to read as follows:

**1613.9 Suspended Ceilings.** Minimum design and installation standards for suspended ceilings shall be determined in accordance with the requirements of Section 2506.2.1 of this code and this section.

**1613.9.1 Scope.** This part contains special requirements for suspended ceilings and lighting systems. Provisions of Section 13.5.6 of ASCE 7 shall apply except as modified herein.

**1613.9.2 General.** The suspended ceilings and lighting systems shall be limited to 6 feet (1828 mm) below the structural deck unless the lateral bracing is designed by a licensed engineer or architect.

**1613.9.3 Sprinkler Heads.** All sprinkler heads (drops) except fire-resistance-rated floor/ceiling or roof/ceiling assemblies, shall be designed to allow for free movement of the sprinkler pipes with oversize rings, sleeves or adaptors through the ceiling tile. Sprinkler heads and other penetrations shall have a 2 in. (50mm) oversize ring, sleeve, or adapter through the ceiling tile to allow for free movement of at least 1 in. (25mm) in all horizontal directions. Alternatively, a swing joint that can accommodate 1 in. (25 mm) of ceiling movement in all horizontal directions is permitted to be provided at the top of the sprinkler head extension.

Sprinkler heads penetrating fire-resistance-rated floor/ceiling or roof/ceiling assemblies shall comply with Section 714 of this code.

**18.04.070 Section 1613.10 is Added**

Section 1613.10 is added to read as follows:

**1613.10 Power Actuated Fasteners.** The provisions of Section 13.4.5 of ASCE 7 shall apply to the design of power actuated fasteners. Power actuated fasteners shall not be used to anchor sill plates or tracks except at interior non-bearing walls not designed as shear walls.

**18.04.080 Section 1613.11 is Added**

Section 1613.11 is added as follows:

**1613.11 Light-gage mudsill anchors.** Light-gage mudsill anchors which are intended to be bent upon installation shall not be used to anchor shear walls. Where light-gage anchors are used at exterior walls not designed as shear walls, they shall be fully protected by the exterior weather barrier assembly or by an approved corrosion-resistant coating.

**Chapter 18.05**  
**AMENDMENTS TO CHAPTER 17; STRUCTURAL TESTS AND SPECIAL**  
**INSPECTIONS, OF THE CALIFORNIA BUILDING CODE**

**Sections:**

**18.05.005 Chapter 17 is Amended**  
**18.05.010 Section 1705.3 is Amended**

**18.05.005 Chapter 17 is Amended**

The following sections of Chapter 17 of the California Building Code, as adopted by Chapter 18.01 hereof, are added, deleted, or amended as follows:

**18.05.010 Section 1705.3 is Amended**

Section 1705.3 is amended to read as follows:

**1705.3 Concrete Construction.** The special inspections and verifications for concrete construction shall be as required by this section and Table 1705.3.

**Exceptions:** Special inspection shall not be required for:

1. Isolated spread concrete footings of buildings three stories or less above grade plane that are fully supported on earth or rock, where the structural design of the footing is based on a specified compressive strength,  $f'c$ , no greater than 2,500 pounds per square inch (psi) (17.2 MPa).
2. Continuous concrete footings supporting walls of buildings three stories or less in height that are fully supported on earth or rock where:
  - 2.1. The footings support walls of light-frame construction;
  - 2.2. The footings are designed in accordance with Table 1809.7; or
  - 2.3. The structural design of the footing is based on a specified compressive strength,  $f'c$ , no greater than 2,500 pounds per square inch (psi) (17.2 MPa), regardless of the compressive strength specified in the construction documents or used in the footing construction.
3. Nonstructural concrete slabs supported directly on the ground, including prestressed slabs on grade, where the effective prestress in the concrete is less than 150 psi (1.03 MPa).
4. Concrete patios, driveways and sidewalks, on grade.

**Chapter 18.06**  
**AMENDMENTS TO CHAPTER 18; SOILS AND FOUNDATIONS, OF THE**  
**CALIFORNIA BUILDING CODE**

**Sections:**

|                  |  |
|------------------|--|
| <b>18.06.005</b> | <b>Chapter 18 is Amended</b>                       |
| <b>18.06.006</b> | <b>Section 1805.1 is Amended</b>                   |
| <b>18.06.010</b> | <b>Section 1807.1.4 is Amended</b>                 |
| <b>18.06.013</b> | <b>Section 1807.1.6 is Amended</b>                 |
| <b>18.06.015</b> | <b>Section 1807.2 is Amended</b>                   |
| <b>18.06.020</b> | <b>Section 1807.3.1 is Amended</b>                 |
| <b>18.06.030</b> | <b>Section 1808.7.2 is Amended</b>                 |
| <b>18.06.040</b> | <b>Section 1809.3 is Amended</b>                   |
| <b>18.06.050</b> | <b>Section 1809.4 is Amended</b>                   |
| <b>18.06.060</b> | <b>Section 1809.7 and Table 1809.7 are Amended</b> |
| <b>18.06.070</b> | <b>Section 1809.12 is Amended</b>                  |
| <b>18.06.080</b> | <b>Section 1810.3.2.4 is Amended</b>               |

**18.06.005 Chapter 18 is Amended**

The following sections of Chapter 18 of the California Building Code, as adopted by Chapter 18.01 hereof, are added, deleted, or amended as follows:

**18.06.006 Section 1805.1 is Amended**

Section 1805.1 is amended to read as follows:

**1805.1 General.** Walls or portions thereof that retain earth and enclose interior spaces and floors below grade shall be waterproofed and dampproofed in accordance with this section, with the exception of those spaces containing groups other than residential and institutional where such omission is not detrimental to the building or occupancy. Ventilation for crawl spaces shall comply with Section 1203.4. Walls retaining 8 feet of soil or more shall have a waterproofing membrane installed in accordance with Section 1805.3.2. Where the geotechnical engineer determines that a waterproofing membrane is not required to protect against corrosion of reinforcing steel, a waterproofing membrane shall not be required.

**18.06.010 Section 1807.1.4 is Amended**

Section 1807.1.4 is amended to read as follows:

**1807.1.4 Permanent wood foundation systems.** Permanent wood foundation systems shall not be permitted.

**18.06.013 Section 1807.1.6 is Amended**

Section 1807.1.6 is amended to read as follows:

**1807.1.6 Prescriptive design of concrete and masonry foundation walls.** Concrete and masonry foundation walls that are laterally supported at the top and bottom shall be permitted to be designed and constructed in accordance with this section. Prescriptive design of foundation walls shall not be used for structures assigned to Seismic Design Category D, E or F.

**18.06.015 Section 1807.2 is Amended**

Section 1807.2 is amended to read as follows:

**1807.2 Retaining walls.** Retaining walls shall be designed in accordance with Section 1807.2.1 through 1807.2.3. Retaining walls assigned to Seismic Design Category D, E or F shall not be constructed of wood.

**18.06.020 Section 1807.3.1 is Amended**

Section 1807.3.1 is amended to read as follows:

**1807.3.1 Limitations.** The design procedures outlined in this section are subject to the following limitations:

1. The frictional resistance for structural walls and slabs on silts and clays shall be limited to one-half of the normal force imposed on the soils by the footing or slab.
2. Posts embedded in earth shall not be used to provide lateral support for structural or nonstructural materials such as plaster, masonry or concrete unless bracing is provided that develops the limited deflection required.

Wood poles shall be treated in accordance with AWP A U1 for sawn timber posts (Commodity Specification A, Use Category 4B) and for round timber posts (Commodity Specification B, Use Category 4B). Wood poles and posts embedded in direct contact with soil shall not be used for structures assigned to Seismic Design Category D, E or F.

**Exception:** Wood poles and posts embedded in direct contact with soil may be used to support non-habitable, non-occupiable structures such as fences when approved by the Building Official.

**18.06.030 Section 1808.7.2 is Amended**

Section 1808.7.2 is amended to read as follows:

**1808.7.2 Foundation setback from descending slope surface.** Foundations on or adjacent to slope surfaces shall be founded in firm material with an embedment and set back from the slope surface sufficient to provide vertical and lateral support for the foundation without detrimental settlement. Except as provided for in Section 1808.7.5 and Figure 1808.7.1, the following setback is deemed adequate to meet the criteria. Where the slope is steeper than 1 unit vertical in 1 unit horizontal (100-percent slope), the required setback shall be measured from an imaginary plane 45 degrees (0.79 rad) to the horizontal, projected upward from the toe of the slope. The setback shall be that determined using Figure 1808.7.1 or 5 feet, whichever is larger.

**18.06.040 Section 1809.3 is Amended**

Section 1809.3 is amended to read as follows:

**1809.3 Stepped footings.** The top surface of footings shall be level. The bottom surface of footings shall be permitted to have a slope not exceeding one unit vertical in 10 units horizontal (10-percent slope). Footings shall be stepped where it is necessary to change the elevation of the top surface of the footing or where the surface of the ground slopes more than one unit vertical in 10 units horizontal (10-percent slope).

For structures assigned to Seismic Design Category D, E or F, the stepping requirement shall also apply to the top surface of grade beams supporting walls. Footings shall be reinforced with a minimum of four #4 steel reinforcing bars. Two bars shall be placed at the top and bottom of the footings as shown in Figure 1809.3.

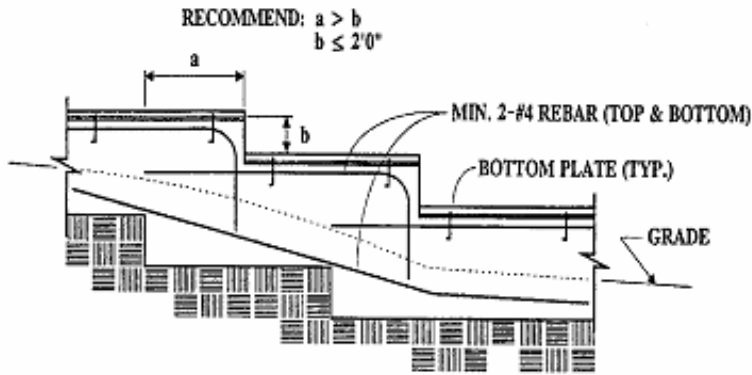

**STEPPED FOUNDATIONS**

**Figure 1809.3**

**18.06.050 Section 1809.4 is Amended**

Section 1809.4 is amended to read as follows:

**1809.4 Depth and width of footings.** Where a geotechnical report is not provided and the presence of expansive soils is unknown, the minimum depth of footings shall be 24 inches (610 mm) for exterior walls and 18 inches (458 mm) for interior bearing walls. Such footings shall be reinforced with a minimum of two #4 rebar at the top and two #4 rebar at the bottom.

**Exception:** The minimum footing depth for unoccupied group U structures or patio structures associated with an R-3 occupancy shall be 12 inches (305 mm).

Otherwise, the minimum depth of footings below the undisturbed ground surface shall be 12 inches (305 mm). Where applicable, the requirements of section 1809.5 shall also be satisfied. The minimum width of footings shall be 12 inches (305 mm).

**18.06.060 Section 1809.7 and Table 1809.7 are Amended**

Section 1809.7 and Table 1809.7 are amended to read as follows:

**1809.7 Prescriptive footings for light-frame construction.** Where a specific design is not provided, concrete or masonry-unit footings supporting walls of light-frame construction shall be permitted to be designed in accordance with Table 1809.7. Prescriptive footings in Table 1809.7 shall not exceed two stories above grade plane for structures assigned to Seismic Design Category D, E or F.

**TABLE 1809.7  
PRESCRIPTIVE FOOTINGS SUPPORTING WALLS OF  
LIGHT-FRAME CONSTRUCTION<sup>a, b, c, d, e</sup>**

| NUMBER OF FLOORS SUPPORTED BY THE FOOTING | WIDTH OF FOOTING (inches) | THICKNESS OF FOOTING (inches) |
|---|---------------------------|-------------------------------|
| 1   | 12                        | 8                             |
| 2   | 15                        | 8                             |

For SI: 1 inch = 25.4 mm, 1 foot = 304.8 mm

a. Depth of footings shall be in accordance with Section 1809.4.

b. The ground under the floor shall be permitted to be excavated to the elevation of the top of the footing.

c. See Section 1905 for additional requirements for concrete footings of structures assigned to Seismic Design Category C, D, E or F.

- d. For thickness of foundation walls, see Section 1807.1.6.
- e. Footings shall be permitted to support a roof addition to the stipulated number of floors. Footings supporting roof only shall be as required for supporting one floor.

**18.06.070 Section 1809.12 is Amended**

Section 1809.12 is amended to read as follows:

**1809.12 Timber footings.** Timber footings shall not be permitted.

**18.06.080 Section 1810.3.2.4 is Amended**

Section 1810.3.2.4 is amended to read as follows:

**1810.3.2.4 Timber.** Timber deep foundation elements shall not be permitted.



**Chapter 18.07**  
**AMENDMENTS TO CHAPTER 19; CONCRETE, OF THE CALIFORNIA BUILDING**  
**CODE**

**Sections:**

- |                  |                                    |
|------------------|------------------------------------|
| <b>18.07.005</b> | <b>Chapter 19 is Amended</b>       |
| <b>18.07.010</b> | <b>Section 1905.1.7 is Amended</b> |

**18.07.005 Chapter 19 is Amended**

The following sections of Chapter 19 of the California Building Code, as adopted by Chapter 18.01 hereof, are added, deleted, or amended as follows:

**18.07.010 Section 1905.1.7 is Amended**

Section 1905.1.7 is amended to read as follows:

**1905.1.7 ACI 318, Section 14.1.4.** Delete ACI 318, Section 14.1.4, and replace with the following:

14.1.4 – Plain concrete in structures assigned to Seismic Design Category C, D, E or F.

14.1.4.1 – Structures assigned to Seismic Design Category C, D, E or F shall not have elements of structural plain concrete, except as follows:

(a) Concrete used for fill with a minimum cement content of two (2) sacks of Portland cement per cubic yard.

(b) Isolated footings of plain concrete supporting pedestals or columns are permitted for buildings of light-frame construction, provided the projection of the footing beyond the face of the supported member does not exceed the footing thickness and the footing supports a single roof or floor.

(c) Plain concrete footings supporting walls are permitted provided the footings have at least two continuous longitudinal reinforcing bars. Bars shall not be smaller than No. 4 and shall have a total area of not less than 0.002 times the gross cross-sectional area of the footing. A minimum of one bar shall be provided at the top and bottom of the footing. Continuity of reinforcement shall be provided at corners and intersections.

In detached one- and two-family dwellings three stories or less in height and constructed with stud-bearing walls, plain concrete footings with at least two continuous longitudinal reinforcing bars not smaller than No. 4 are permitted to have a total area of less than 0.002 times the gross cross-sectional area of the footing.

## Chapter 18.08

### AMENDMENTS TO CHAPTER 23; WOOD, OF THE CALIFORNIA BUILDING CODE

#### Sections:

|                  |   |
|------------------|---|
| <b>18.08.005</b> | <b>Chapter 23 is Amended</b>                                |
| <b>18.08.010</b> | <b>Section 2304.10.1 is Amended</b>                         |
| <b>18.08.011</b> | <b>Section 2304.10.2.1 is Added</b>                         |
| <b>18.08.020</b> | <b>Section 2304.10.7 is Amended</b>                         |
| <b>18.08.030</b> | <b>Section 2304.10.8 is Added</b>                           |
| <b>18.08.040</b> | <b>Section 2304.12.5 is Amended</b>                         |
| <b>18.08.060</b> | <b>Section 2306.2 is Amended</b>                            |
| <b>18.08.070</b> | <b>Tables 2306.2(3), 2306.2(4), and 2306.2(5) are Added</b> |
| <b>18.08.080</b> | <b>Section 2306.3 is Amended</b>                            |
| <b>18.08.090</b> | <b>Section 2307.2 is Added</b>                              |
| <b>18.08.100</b> | <b>Table 2306.3(4) is Added</b>                             |
| <b>18.08.110</b> | <b>Table 2308.6.1 is Amended</b>                            |
| <b>18.08.120</b> | <b>Section 2308.6.5 is Amended</b>                          |
| <b>18.08.130</b> | <b>Section 2308.6.8.1 is Amended</b>                        |
| <b>18.08.140</b> | <b>Section 2308.6.9 is Amended</b>                          |

#### **18.08.005 Chapter 23 is Amended**

The following sections of Chapter 23 of the California Building Code, as adopted by Chapter 18.01 hereof, are added, deleted, or amended as follows:

#### **18.08.010 Section 2304.10.1 is Amended**

Section 2304.10.1 is amended to read as follows:

**2304.10.1 Fastener requirements.** Connections for wood members shall be designed in accordance with the appropriate methodology in Section 2301.2. The number and size of fasteners connecting wood members shall not be less than that set forth in Table 2304.10.1. Staple fasteners in Table 2304.10.1 shall not be used to resist or transfer seismic forces in structures assigned to Seismic Design Category D, E or F.

**Exception:** Staples may be used to resist or transfer seismic forces when the allowable shear values are substantiated by cyclic testing and approved by the Building Official.

#### **18.08.011 Section 2304.10.2.1 is Added**

Section 2304.10.2.1 is added to read as follows:

**2304.10.2.1 Quality of Nails.** Mechanically driven nails used in wood structural panel shear walls shall meet the same dimensions as that required for hand-driven nails, including diameter, minimum length and minimum head diameter. Clipped head or box nails are not permitted in new construction. The allowable design value for clipped head nails in existing construction may be taken at no more than the nail-head-area ratio of that of the same size hand-driven nails.

#### **18.08.020 Section 2304.10.7 is Amended**

Section 2304.10.7 is amended to read as follows:

**2304.10.7 Framing requirements.** Wood columns and posts shall be framed to provide full end bearing. Alternatively, column-and-post end connections shall be designed to resist the full compressive loads, neglecting end-bearing capacity. Column-and-post end connections shall be fastened to resist lateral and net induced uplift forces. The minimum lateral design force for column and post end connections shall be

2% of the total axial compressive force acting on the column or post, but shall not be less than the force determined by analysis. The minimum lateral design force shall be assumed to act in any direction.

**18.08.030 Section 2304.10.8 is Added**

Section 2304.10.8 is added to read as follows:

**2304.10.8 Nails, staples, or spikes in withdrawal.** Nails, staples, or spikes shall not be used in withdrawal to resist the loads prescribed by this code.

**Exceptions:**

1. Fasteners connecting finish materials weighing 10 psf or less.
2. Fasteners connecting sheathing may be used to resist wind uplift loads.
3. Fasteners connecting roofing or cladding, when specifically approved by this code or by an approved listing or testing authority.
4. Fasteners connecting mechanical or electrical components weighing 20 lb or less, or in the case of a distributed system, 5 lb/ft or less.

**18.08.040 Section 2304.12.5 is Amended**

Section 2304.12.5 is amended to read as follows:

**2304.12.5 Wood used in retaining walls and cribs.** Wood installed in retaining or crib walls shall be preservative treated in accordance with AWPA U1 for soil and fresh water use. Wood shall not be used in retaining or crib walls for structures assigned to Seismic Design Category D, E, or F.

**18.08.060 Section 2306.2 is Amended**

Section 2306.2 is amended to read as follows:

**2306.2 Wood-frame diaphragms.** Wood-frame diaphragms shall be designed and constructed in accordance with AWC SDPWS. Where panels are fastened to framing members with staples, requirements and limitations of AWC SDPWS shall be met and the allowable shear values set forth in Table 2306.2(1) or 2306.2(2) shall only be permitted for structures assigned to Seismic Design Category A, B, or C.

**Exception:** Allowable shear values where panels are fastened to framing members with staples may be used if such values are substantiated by cyclic testing and approved by the Building Official.

The allowable shear values in Tables 2306.2(1) and 2306.2(2) are permitted to be increased 40 percent for wind design.

Wood structural panel diaphragms used to resist seismic forces in structures assigned to Seismic Design Category D, E or F shall be applied directly to the framing members.

**Exception:** Wood structural panel diaphragms are permitted to be fastened over solid lumber planking or laminated decking, provided the panel joints and lumber planking or laminated decking joints do not coincide.

**18.08.070 Tables 2306.2(3), 2306.2(4), and 2306.2(5) are Added**

Tables 2306.2(3), 2306.2(4), and 2306.2(5) are added as follows:

**Table 2306.2(3)**  
**UNBLOCKED Wood Structural Panel DIAPHRAGMS with Framing of Douglas-Fir Larch or Southern Pine**  
**Allowable (ASD) Unit Shear Capacities (pounds per foot)**

| Sheathing Grade                              | Common Nail Size | Minimum Fastener Penetration in Framing (in.) | Minimum Nominal Panel Thickness (in.) | Minimum Nominal Width of Nailed Face at Supported Edges and Boundaries (in.) | SEISMIC  |                 | WIND       |                 |
|--|------------------|---|---------------------------------------|--|--|-----------------|------------|-----------------|
|  |                  |   |                                       |  | 6 in. Nail Spacing at diaphragm boundaries and supported panel edges |                 |            |                 |
|  |                  |   |                                       |  | Case 1   | Cases 2,3,4,5,6 | Case 1     | Cases 2,3,4,5,6 |
| Structural I                                 | 8d               | 1-3/8   | 3/8                                   | 2<br>3   | 240<br>265   | 180<br>200      | 335<br>370 | 252<br>280      |
|  | 10d              | 1-1/2   | 15/32                                 | 2<br>3   | 285<br>320   | 215<br>240      | 400<br>447 | 300<br>335      |
| Sheathing and Single-Floor (DOC PS1 and PS2) | 6d               | 1-1/4   | 3/8                                   | 2<br>3   | 165<br>185   | 125<br>140      | 230<br>260 | 175<br>195      |
|  | 8d               | 1-3/8   | 3/8                                   | 2<br>3   | 215<br>240   | 160<br>180      | 300<br>335 | 225<br>252      |
|  |                  |   | 7/16                                  | 2<br>3   | 230<br>255   | 170<br>190      | 322<br>357 | 237<br>265      |
|  |                  |   | 15/32                                 | 2<br>3   | 240<br>265   | 180<br>200      | 335<br>370 | 252<br>280      |
|  | 10d              | 1-1/2   | 15/32                                 | 2<br>3   | 255<br>290   | 190<br>215      | 357<br>405 | 265<br>300      |
|  |                  |   | 19/32                                 | 2<br>3   | 285<br>320   | 215<br>240      | 400<br>447 | 300<br>335      |

a. See AWC SDPWS for the following: For general construction requirements see 4.2.6. For specific requirements see 4.2.7.1 for wood structural panel diaphragms. See Appendix A for common nail dimensions.

b. For species and grades of framing other than Douglas-Fir-Larch or Southern Pine, reduced nominal unit shear capacities shall be determined by multiplying the tabulated nominal unit shear capacity by the Specific Gravity Adjustment Factor =  $[1-(0.5-G)]$ , where G = Specific Gravity of the framing lumber from the NDS (Table 12.3.3A). The Specific Gravity Adjustment Factor shall not be greater than 1.

c. See AWC SDPWS Table 4.2C for Case definitions.

d. See AWC SDPWS Table 4.2C for the apparent shear stiffness values ( $G_a$ ).

**Table 2306.2(4)**  
**BLOCKED Wood Structural Panel DIAPHRAGMS with Framing of Douglas-Fir Larch or Southern Pine**  
**Allowable (ASD) Unit Shear Capacities (pounds per foot)**

| Sheathing Grade                              | Common Nail Size | Minimum Fastener Penetration in Framing Member or Blocking (in.) | Minimum Nominal Panel Thickness (in.) | Minimum Nominal Width of Nailed Face at Adjoining Panel Edges and Boundaries (in.) | SEISMIC  |     |       |     | WIND   |     |       |      |
|--|------------------|--|---------------------------------------|--|--|-----|-------|-----|--|-----|-------|------|
|  |                  |  |                                       |  | Nail Spacing (in.) at diaphragm boundaries (all cases), at continuous panel edges parallel to load (Cases 3 & 4), and at all panel edges (Cases 5 & 6) |     |       |     | Nail Spacing (in.) at diaphragm boundaries (all cases), at continuous panel edges parallel to load (Cases 3 & 4), and at all panel edges (Cases 5 & 6) |     |       |      |
|  |                  |  |                                       |  | 6  | 4   | 2-1/2 | 2   | 6  | 4   | 2-1/2 | 2    |
|  |                  |  |                                       |  | Nail Spacing (in.) at other panel edges (Cases 1, 2, 3, & 4)   |     |       |     | Nail Spacing (in.) at other panel edges (Cases 1, 2, 3, & 4)   |     |       |      |
|  |                  |  |                                       |  | 6  | 6   | 4     | 3   | 6  | 6   | 4     | 3    |
| Structural I                                 | 8d               | 1-3/8  | 3/8                                   | 2  | 270  | 360 | 530   | 600 | 372  | 505 | 742   | 840  |
|  |                  |  |                                       | 3  | 300  | 400 | 600   | 675 | 420  | 560 | 840   | 945  |
|  | 10d              | 1-1/2  | 15/32                                 | 2  | 320  | 425 | 640   | 730 | 447  | 595 | 895   | 1022 |
|  |                  |  |                                       | 3  | 360  | 480 | 720   | 820 | 505  | 672 | 1007  | 1147 |
| Sheathing and Single-Floor (DOC PS1 and PS2) | 6d               | 1-1/4  | 3/8                                   | 2  | 185  | 250 | 375   | 420 | 260  | 350 | 525   | 587  |
|  |                  |  |                                       | 3  | 210  | 280 | 420   | 475 | 295  | 392 | 587   | 665  |
|  | 8d               | 1-3/8  | 3/8                                   | 2  | 240  | 320 | 480   | 545 | 335  | 447 | 672   | 762  |
|  |                  |  |                                       | 3  | 270  | 360 | 540   | 610 | 377  | 505 | 755   | 855  |
|  |                  |  | 7/16                                  | 2  | 255  | 340 | 505   | 575 | 357  | 475 | 707   | 805  |
|  |                  |  |                                       | 3  | 285  | 380 | 570   | 645 | 400  | 532 | 797   | 902  |
|  | 15/32            | 2  | 270                                   | 360  | 530  | 600 | 372   | 505 | 742  | 840 |       |      |
|  |                  | 3  | 300                                   | 400  | 600  | 675 | 420   | 560 | 840  | 945 |       |      |
|  | 10d              | 1-1/2  | 15/32                                 | 2  | 290  | 385 | 575   | 655 | 405  | 540 | 805   | 917  |
|  |                  |  |                                       | 3  | 325  | 430 | 650   | 735 | 455  | 602 | 910   | 1030 |
|  |                  |  | 19/32                                 | 2  | 320  | 425 | 640   | 730 | 497  | 595 | 895   | 1022 |
|  |                  |  |                                       | 3  | 360  | 480 | 720   | 820 | 505  | 672 | 1007  | 1147 |

a. See AWC SDPWS for the following: For general construction requirements see 4.2.6. For specific requirements see 4.2.7.1 for wood structural panel diaphragms. See Appendix A for common nail dimensions.

b. For species and grades of framing other than Douglas-Fir-Larch or Southern Pine, reduced nominal unit shear capacities shall be determined by multiplying the tabulated nominal unit shear capacity by the Specific Gravity Adjustment Factor =  $[1-(0.5-G)]$ , where G = Specific Gravity of the framing lumber from the NDS (Table 12.3.3A). The Specific Gravity Adjustment Factor shall not be greater than 1.

c. See AWC SDPWS Table 4.2A for Case definitions.

d. See AWC SDPWS Table 4.2A for the apparent shear stiffness values ( $G_a$ ).

**Table 2306.2(5)**  
**Blocked Wood Structural Panel DIAPHRAGMS with Framing of Douglas-Fir Larch or Southern Pine**  
**UTILIZING MULTIPLE ROWS OF FASTENERS (HIGH-LOAD DIAPHRAGMS)**  
**Allowable (ASD) Unit Shear Capacities (pounds per foot)**

| Sheathing Grade                              | Common Nail Size | Minimum Fastener Penetration in Framing Member or Blocking (in.) | Minimum Nominal Panel Thickness (in.) | Minimum Nominal Width of Nailed Face at Adjoining Panel Edges and Boundaries (in.) | Lines of Fasteners | SEISMIC  |      |       |      | WIND   |      |       |      |
|--|------------------|--|---------------------------------------|--|--------------------|--|------|-------|------|--|------|-------|------|
|  |                  |  |                                       |  |                    | Nail Spacing (in.) at diaphragm boundaries (all cases), at continuous panel edges parallel to load (Cases 3 & 4), and at all panel edges (Cases 5 & 6) |      |       |      |  |      |       |      |
|  |                  |  |                                       |  |                    | 4  |      | 2-1/2 |      | 4  |      | 2-1/2 |      |
|  |                  |  |                                       |  |                    | Nail Spacing (in.) at other panel edges (Cases 1, 2, 3, & 4)   |      |       |      | Nail Spacing (in.) at other panel edges (Cases 1, 2, 3, & 4) |      |       |      |
|  |                  |  |                                       |  |                    | 6  | 4    | 4     | 3    | 6  | 4    | 4     | 3    |
| Structural I                                 | 10d              | 1-1/2  | 15/32                                 | 3  | 2                  | 605  | 815  | 875   | 1150 | 847  | 1140 | 1225  | 1610 |
|  |                  |  |                                       | 4  | 2                  | 700  | 915  | 1005  | 1290 | 980  | 1280 | 1407  | 1805 |
|  |                  |  |                                       | 4  | 3                  | 875  | 1220 | 1285  | 1395 | 1225   | 1707 | 1800  | 1952 |
|  |                  |  | 19/32                                 | 3  | 2                  | 670  | 880  | 965   | 1255 | 937  | 1232 | 1350  | 1757 |
|  |                  |  |                                       | 4  | 2                  | 780  | 990  | 1110  | 1440 | 1092   | 1385 | 1555  | 2015 |
|  |                  |  |                                       | 4  | 3                  | 965  | 1320 | 1405  | 1790 | 1350   | 1847 | 1967  | 2505 |
|  |                  |  | 23/32                                 | 3  | 2                  | 730  | 955  | 1050  | 1365 | 1022   | 1337 | 1470  | 1910 |
|  |                  |  |                                       | 4  | 2                  | 855  | 1070 | 1210  | 1565 | 1197   | 1497 | 1695  | 2190 |
|  |                  |  |                                       | 4  | 3                  | 1050   | 1430 | 1525  | 1800 | 1470   | 2002 | 2135  | 2520 |
| Sheathing and Single-Floor (DOC PS1 and PS2) | 10d              | 1-1/2  | 15/32                                 | 3  | 2                  | 525  | 725  | 765   | 1010 | 735  | 1015 | 1070  | 1415 |
|  |                  |  |                                       | 4  | 2                  | 605  | 815  | 875   | 1105 | 847  | 1140 | 1225  | 1547 |
|  |                  |  |                                       | 4  | 3                  | 765  | 1085 | 1130  | 1195 | 1070   | 1520 | 1582  | 1672 |
|  |                  |  | 19/32                                 | 3  | 2                  | 650  | 860  | 935   | 1225 | 910  | 1205 | 1310  | 1715 |
|  |                  |  |                                       | 4  | 2                  | 755  | 965  | 1080  | 1370 | 1057   | 1350 | 1512  | 1917 |
|  |                  |  |                                       | 4  | 3                  | 935  | 1290 | 1365  | 1485 | 1310   | 1805 | 1910  | 2080 |
|  |                  |  | 23/32                                 | 3  | 2                  | 710  | 935  | 1020  | 1335 | 995  | 1310 | 1427  | 1870 |
|  |                  |  |                                       | 4  | 2                  | 825  | 1050 | 1175  | 1445 | 1155   | 1470 | 1645  | 2022 |
|  |                  |  |                                       | 4  | 3                  | 1020   | 1400 | 1480  | 1565 | 1427   | 1960 | 2072  | 2190 |

- a. See AWC SDPWS for the following: For general construction requirements see 4.2.6. For specific requirements see 4.2.7.1 for wood structural panel diaphragms. See Figure 4C for nailing diagrams. See Appendix A for common nail dimensions.
- b. For species and grades of framing other than Douglas-Fir-Larch or Southern Pine, reduced nominal unit shear capacities shall be determined by multiplying the tabulated nominal unit shear capacity by the Specific Gravity Adjustment Factor =  $[1-(0.5-G)]$ , where G = Specific Gravity of the framing lumber from the NDS (Table 12.3.3A). The Specific Gravity Adjustment Factor shall not be greater than 1.
- c. See AWC SDPWS Table 4.2B for Case definitions.
- d. See AWC SDPWS Table 4.2B for the apparent shear stiffness values ( $G_a$ ).

**18.08.080 Section 2306.3 is Amended**

Section 2306.3 is amended to read as follows:

**2306.3 Wood-frame shear walls.** Wood-frame shear walls shall be designed and constructed in accordance with AWC SDPWS. Where Allowable Stress Design is used, table 2306.3(4) may be applied. Application of Table 4.3A of AWC SDPWS shall include the following:

1. Wood structural panel thickness for shear walls shall not be less than 3/8 inch thick. When 3/8-inch or 7/16-inch thick panels are used, studs shall not be spaced at more than 16 inches on center.
2. The maximum nominal unit shear capacities for 3/8 inch wood structural panels resisting seismic forces shall be 400 pounds per linear foot (plf).

**Exception:** Other nominal unit shear capacities may be permitted if such values are substantiated by cyclic testing and approved by the Building Official.

3. Nails shall be placed not less than 1/2 inch in from the panel edges and not less than 3/8 inch from the edge of the connecting members for shear greater than 350 plf using ASD or 500 plf using LRFD. Nails shall be placed not less than 3/8 inch from panel edges and not less than 1/4 inch from the edge of the connecting members for shears of 350 plf or less using ASD or 500 plf or less using LRFD.

**2306.3.1** Application of Table 4.3B of AWC SDPWS shall not be permitted.

**2306.3.2** See section 2505.4 as amended for provisions regarding gypsum board and portland cement plaster shear walls.

**2306.3.3** Shear walls using panels fastened with staples shall not be permitted.

**Exception:** Allowable shear values where panels are fastened to framing members with staples may be used if such values are substantiated by cyclic testing and approved by the Building Official.

**2306.3.4** The allowable shear values in Tables 2306.3(1) and 2306.3(2) are permitted to be increased 40 percent for wind design. Panels complying with ANSI/APA PRP-210 shall be permitted to use design values for Plywood Siding in the AWC SDPWS.

**18.08.090 Section 2307.2 is Added**

Section 2307.2 is added to read as follows:

**2307.2 Wood-frame shear walls.** Wood-frame shear walls shall be designed and constructed in accordance with Section 2306.3 as applicable.

**18.08.100 Table 2306.3(4) is Added**

Table 2306.3(4) is added as follows:

**TABLE 2306.3(4)**  
**WOOD STRUCTURAL PANEL SHEAR WALLS with Framing of Douglas-Fir Larch or Southern Pine**  
**Allowable (ASD) Shear Capacities (pounds per foot)**

| Sheathing Material                                    | Minimum Nominal Panel Thickness (in.) | Minimum Fastener Penetration into Framing or Blocking (in.) | Nail Size (common) | SEISMIC                           |      |      |      | WIND                              |     |      |       |
|---|---------------------------------------|---|--------------------|-----------------------------------|------|------|------|-----------------------------------|-----|------|-------|
|   |                                       |   |                    | Panel Edge Fastener Spacing (in.) |      |      |      | Panel Edge Fastener Spacing (in.) |     |      |       |
|   |                                       |   |                    | 6                                 | 4    | 3    | 2    | 6                                 | 4   | 3    | 2     |
| Wood Structural Panels – Structural I                 | 3/8                                   | 1-3/8   | 8d                 | 200                               | 200  | 200  | 200* | 322                               | 505 | 645  | 855*  |
|   | 7/16                                  |   |                    | 255                               | 395* | 505* | 670* | 357                               | 552 | 707  | 937*  |
|   | 15/32                                 |   |                    | 280                               | 430* | 550* | 730* | 392                               | 602 | 770  | 1022* |
|   | 15/32                                 | 1-1/2   | 10d                | 340                               | 510* | 665* | 870* | 475                               | 715 | 930* | 1217* |
| Wood Structural Panels – Sheathing (DOC PS 1 or PS 2) | 3/8                                   | 1-1/4   | 6d                 | 200                               | 200  | 200  | 200* | 280                               | 420 | 545  | 715*  |
|   | 3/8                                   | 1-3/8   | 8d                 | 200                               | 200  | 200  | 200* | 307                               | 447 | 575  | 742*  |
|   | 7/16                                  |   |                    | 240                               | 350  | 450* | 585* | 335                               | 490 | 630  | 820*  |
|   | 15/32                                 |   |                    | 260                               | 380* | 490* | 640* | 365                               | 532 | 685  | 895*  |
|   |                                       | 15/32   | 1-1/2              | 10d                               | 310  | 460* | 600* | 770*                              | 435 | 645  | 840*  |
|   | 19/32                                 | 340   |                    |                                   | 510* | 665* | 870* | 475                               | 715 | 930* | 1217* |
| Plywood Siding  | 3/8                                   | 1-1/4   | 6d                 | 140                               | 200  | 200  | 200* | 195                               | 295 | 385  | 505*  |
|   |                                       | 1-3/8   | 8d                 | 160                               | 200  | 200  | 200* | 225                               | 335 | 435  | 575*  |

\* Framing members and blocking at adjoining panel edges shall be 3” nominal or greater per AWC SDPWS Section 4.3.7.1, item 5.

- a. Where panels are applied on both faces of a wall and nail spacing is less than 6” on center on either side, panel joints shall be offset to fall on different framing members, or framing shall be 3” nominal or thicker at adjoining panel edges and nails at all panel edges shall be staggered.
- b. Where the width of framing members is required to be 3” nominal, two 2” nominal members shall be permitted provided they are fastened together to transfer the shear between members.
- c. Where 3/8” or 7/16” sheathing is used, studs shall not be spaced more than 16” on center. Otherwise, studs shall not be spaced at more than 24” on center.
- d. Where studs are spaced at 24” on center, nailing to intermediate framing shall be spaced at 6” on center maximum. Where studs are spaced less than 24” on center, nailing to intermediate framing shall be spaced at 12” on center maximum.
- e. Steel plate washers shall be provided at foundation anchor bolts as required by AWC SDPWS Section 4.3.6.4.3. When required, plate washers shall not be less than 0.229"x3"x3" in size. The hole in the plate washer shall be permitted to be diagonally slotted with a width of up to 3/16" larger than the bolt diameter and a slot length not to exceed 1-3/4", provided a standard cut washer is placed between the plate washer and the nut.
- f. Allowable shear values for 7/16” sheathing are permitted to be increased to values shown for 15/32” sheathing with the same nailing provided panels are applied with long dimension across studs.
- g. Galvanized nails shall be hot dipped or tumbled.
- h. Nails shall be placed not less than 1/2” in from panel edges and not less than 3/8” from the edge of the connecting members for shears greater than 350 plf. Nails shall not be placed not less than 3/8” from panel edges and not less than 1/4” from the edge of the connecting members for shears of 350 plf or less.
- i. See AWC SDPWS for the following: For general construction requirements see 4.3.6. For specific requirements for wood structural panel shearwalls see 4.3.7.1. For shear wall aspect ratios and capacity adjustments see 4.3.4. For the apparent shear stiffness values ( $G_a$ ), see Table 4.3A. See Appendix A for common nail dimensions.
- j. For species and grades of framing other than Douglas-Fir-Larch or Southern Pine, reduced nominal unit shear capacities shall be determined by multiplying the tabulated nominal unit shear capacity by the Specific Gravity Adjustment Factor =  $[1-(0.5-G)]$ , where  $G$  = Specific Gravity of the framing lumber from the NDS (Table 12.3.3A). The Specific Gravity Adjustment Factor shall not be greater than 1.



18.08.110 Table 2308.6.1 is Amended

Table 2308.6.1 is amended as follows:

TABLE 2308.6.1<sup>a</sup>  
WALL BRACING REQUIREMENTS

| SEISMIC DESIGN CATEGORY   | STORY CONDITION (SEE SECTION 2308.2) | MAXIMUM SPACING OF BRACED WALL LINES | BRACED PANEL LOCATION, SPACING (O.C.) AND MINIMUM PERCENTAGE (X) |  |  | MAXIMUM DISTANCE OF BRACED WALL PANELS FROM EACH END OF BRACED WALL LINE |
|---------------------------|--------------------------------------|--------------------------------------|--|--|--|--|
|                           |                                      |                                      | Bracing method <sup>b</sup>                                      |  |  |  |
|                           |                                      |                                      | LIB  | DWB, WSP   | SFB, PBS, PCP, HPS, GB <sup>c,d</sup>  |  |
| A and B                   |                                      | 35'- 0"                              | Each end and ≤ 25'- 0" o.c.                                      | Each end and ≤ 25'- 0" o.c.  | Each end and ≤ 25'- 0" o.c.  | 12'- 6"  |
|                           |                                      | 35'- 0"                              | Each end and ≤ 25'- 0" o.c.                                      | Each end and ≤ 25'- 0" o.c.  | Each end and ≤ 25'- 0" o.c.  | 12'- 6"  |
|                           |                                      | 35'- 0"                              | NP   | Each end and ≤ 25'- 0" o.c.  | Each end and ≤ 25'- 0" o.c.  | 12'- 6"  |
| C                         |                                      | 35'- 0"                              | NP   | Each end and ≤ 25'- 0" o.c.  | Each end and ≤ 25'- 0" o.c.  | 12'- 6"  |
|                           |                                      | 35'- 0"                              | NP   | Each end and ≤ 25'- 0" o.c. (minimum 25% of wall length) <sup>e</sup>                                | Each end and ≤ 25'- 0" o.c. (minimum 25% of wall length) <sup>e</sup>                            | 12'- 6"  |
| D and E<br><u>f, g, h</u> |                                      | 25'- 0"                              | NP   | $S_{DS} < 0.50$ : Each end and ≤ 25'- 0" o.c. (minimum 21% of wall length) <sup>e</sup>              | $S_{DS} < 0.50$ : Each end and ≤ 25'- 0" o.c. (minimum 43% of wall length) <sup>e</sup>          | 8'- 0"   |
|                           |                                      |                                      |  | $0.5 \leq S_{DS} < 0.75$ : Each end and ≤ 25'- 0" o.c. (minimum 32% of wall length) <sup>e</sup>     | $0.5 \leq S_{DS} < 0.75$ : Each end and ≤ 25'- 0" o.c. (minimum 59% of wall length) <sup>e</sup> |  |
|                           |                                      |                                      |  | $0.75 \leq S_{DS} \leq 1.00$ : Each end and ≤ 25'- 0" o.c. (minimum 37% of wall length) <sup>e</sup> | $0.75 \leq S_{DS} \leq 1.00$ : Each end and ≤ 25'- 0" o.c. (minimum 75% of wall length)          |  |
|                           |                                      |                                      |  | $S_{DS} > 1.00$ : Each end and ≤ 25'- 0" o.c. (minimum 48% of wall length) <sup>e</sup>              | $S_{DS} > 1.00$ : Each end and ≤ 25'- 0" o.c. (minimum 100% of wall length) <sup>e</sup>         |  |

For SI: 1 inch = 25.4 mm, 1 foot = 304.8 mm.

NP = Not Permitted.

a. This table specifies minimum requirements for braced wall panels along interior or exterior braced wall lines.

b. See Section 2308.6.3 for full description of bracing methods.

c. For Method GB, gypsum wallboard applied to framing supports that are spaced at 16 inches on center.

d. The required lengths shall be doubled for gypsum board applied to only one face of a braced wall panel.

e. Percentage shown represents the minimum amount of bracing required along the building length (or wall length if the structure has an irregular shape).

f. DWB, SFB, PBS, and HPS wall braces are not permitted in Seismic Design Categories D or E.

g. Minimum length of panel bracing of one face of the wall for WSP sheathing shall be at least 4'-0" long or both faces of the wall for GB or PCP sheathing shall be at least 8'-0" long; h/w ratio shall not exceed 2:1. Wall framing to which sheathing used for bracing is applied shall be nominal 2 inch wide (actual 1 1/2 inch (38 mm) or larger members and spaced a maximum of 16 inches on center. Braced wall panel construction types shall not be mixed within a braced wall line.

h. WSP sheathing shall be a minimum of 15/32" thick nailed with 8d common placed 3/8 inches from panel edges and spaced not more than 6 inches on center and 12 inches on center along intermediate framing members.

### 18.08.120 Section 2308.6.5 is Amended

Section 2308.6.5 is amended as follows:

**2308.6.5 Alternative bracing.** An alternate braced wall (ABW) or a portal frame with hold-downs (PFH) described in this section is permitted to substitute for a 48-inch (1219 mm) braced wall panel of Method DWB, WSP, SFB, PBS, PCP or HPS. For Method GB, each 96-inch (2438 mm) section (applied to one face) or 48-inch (1219 mm) section (applied to both faces) or portion thereof required by Table 2308.6.1 is permitted to be replaced by one panel constructed in accordance with Method ABW or PFH.

**2308.6.5.1 Alternate braced wall (ABW).** An ABW shall be constructed in accordance with this section and Figure 2308.6.5.1. In one-story buildings, each panel shall have a length of not less than 2 feet 8 inches (813 mm) and a height of not more than 10 feet (3048 mm). Each panel shall be sheathed on one face with 3/8-inch (3.2 mm) minimum-thickness wood structural panel sheathing nailed with 8d common or galvanized box nails in accordance with Table 2304.10.1 and blocked at wood structural panel edges. For structures assigned to Seismic Design Category D or E, each panel shall be sheathed on one face with 15/32-inch-minimum-thickness (11.9 mm) wood structural panel sheathing nailed with 8d common nails spaced 3 inches on panel edges, 3 inches at intermediate supports. Two anchor bolts installed in accordance with Section 2308.3.1 shall be provided in each panel. Anchor bolts shall be placed at each panel outside quarter points. Each panel end stud shall have a hold-down device fastened to the foundation, capable of providing an approved uplift capacity of not less than 1,800 pounds (8006 N). The hold-down device shall be installed in accordance with the manufacturer's recommendations. The ABW shall be supported directly on a foundation or on floor framing supported directly on a foundation that is continuous across the entire length of the braced wall line. This foundation shall be reinforced with not less than one No. 4 bar top and bottom. Where the continuous foundation is required to have a depth greater than 12 inches (305 mm), a minimum 12-inch by 12-inch (305 mm by 305 mm) continuous footing or turned-down slab edge is permitted at door openings in the braced wall line. This continuous footing or turned-down slab edge shall be reinforced with not less than one No. 4 bar top and bottom. This reinforcement shall be lapped 24 inches (610 mm) with the reinforcement required in the continuous foundation located directly under the braced wall line.

Where the ABW is installed at the first story of two-story buildings, the wood structural panel sheathing shall be provided on both faces, three anchor bolts shall be placed at one-quarter points and tie-down device uplift capacity shall be not less than 3,000 pounds (13 344 N).

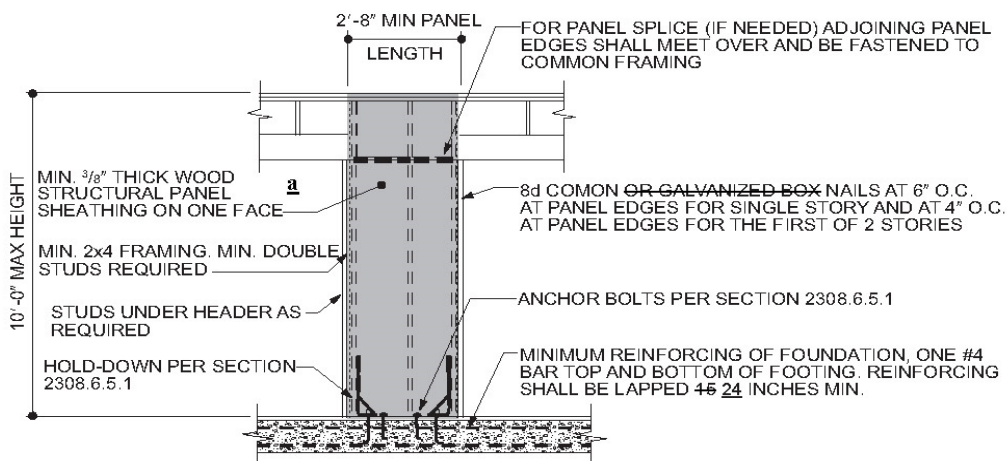

For SI: 1 inch = 25.4 mm, 1 foot = 304.8 mm.

**a.** For structures assigned to Seismic Design Category D or E, sheathed on one face with 15/32-inch-minimum-thickness (11.9 mm) wood structural panel sheathing.

**FIGURE 2308.6.5.1  
ALTERNATE BRACED WALL PANEL (ABW)**

**2308.6.5.2 Portal frame with hold-downs (PFH).** A PFH shall be constructed in accordance with this section and Figure 2308.6.5.2. The adjacent door or window opening shall have a full-length header.

In one-story buildings, each panel shall have a length of not less than 16 inches (406 mm) and a height of not more than 10 feet (3048 mm). Each panel shall be sheathed on one face with a single layer of 3/8-inch (9.5 mm) minimum-thickness wood structural panel sheathing nailed with 8d common or galvanized box nails in accordance with Figure 2308.6.5.2. For structures assigned to Seismic Design Category D or E, each panel shall be sheathed on one face with 15/32-inch-minimum-thickness (11.9 mm) wood structural panel sheathing nailed with 8d common nails spaced 3 inches on panel edges, 3 inches at intermediate supports and in accordance with Figure 2308.6.5.2. The wood structural panel sheathing shall extend up over the solid sawn or glued-laminated header and shall be nailed in accordance with Figure 2308.6.5.2. A built-up header consisting of at least two 2-inch by 12-inch (51 mm by 305 mm) boards, fastened in accordance with Item 24 of Table 2304.10.1 shall be permitted to be used. A spacer, if used, shall be placed on the side of the built-up beam opposite the wood structural panel sheathing. The header shall extend between the inside faces of the first full-length outer studs of each panel. The clear span of the header between the inner studs of each panel shall be not less than 6 feet (1829 mm) and not more than 18 feet (5486 mm) in length. A strap with an uplift capacity of not less than 1,000 pounds (4,400 N) shall fasten the header to the inner studs opposite the sheathing. One anchor bolt not less than 5/8 inch (15.9 mm) diameter and installed in accordance with Section 2308.3.1 shall be provided in the center of each sill plate. The studs at each end of the panel shall have a hold-down device fastened to the foundation with an uplift capacity of not less than 3,500 pounds (15 570 N).

Where a panel is located on one side of the opening, the header shall extend between the inside face of the first full-length stud of the panel and the bearing studs at the other end of the opening. A strap with an uplift capacity of not less than 1,000 pounds (4400 N) shall fasten the header to the bearing studs. The bearing studs shall also have a hold-down device fastened to the foundation with an uplift capacity of not less than 1,000 pounds (4400 N). The hold-down devices shall be an embedded strap type, installed in accordance with the manufacturer's recommendations. The PFH panels shall be supported directly on a foundation that is continuous across the entire length of the braced wall line. This foundation shall be reinforced with not less than one No. 4 bar top and bottom. Where the continuous foundation is required to have a depth greater than 12 inches (305 mm), a minimum 12-inch by 12-inch (305 mm by 305 mm) continuous footing or turned-down-slab edge is permitted at door openings in the braced wall line. This continuous footing or turned-down slab edge shall be reinforced with not less than one No. 4 bar top and bottom. This reinforcement shall be lapped not less than 24 inches (610 mm) with the reinforcement required in the continuous foundation located directly under the braced wall line.

Where a PFH is installed at the first story of two-story buildings, each panel shall have a length of not less than 24 inches (610 mm).

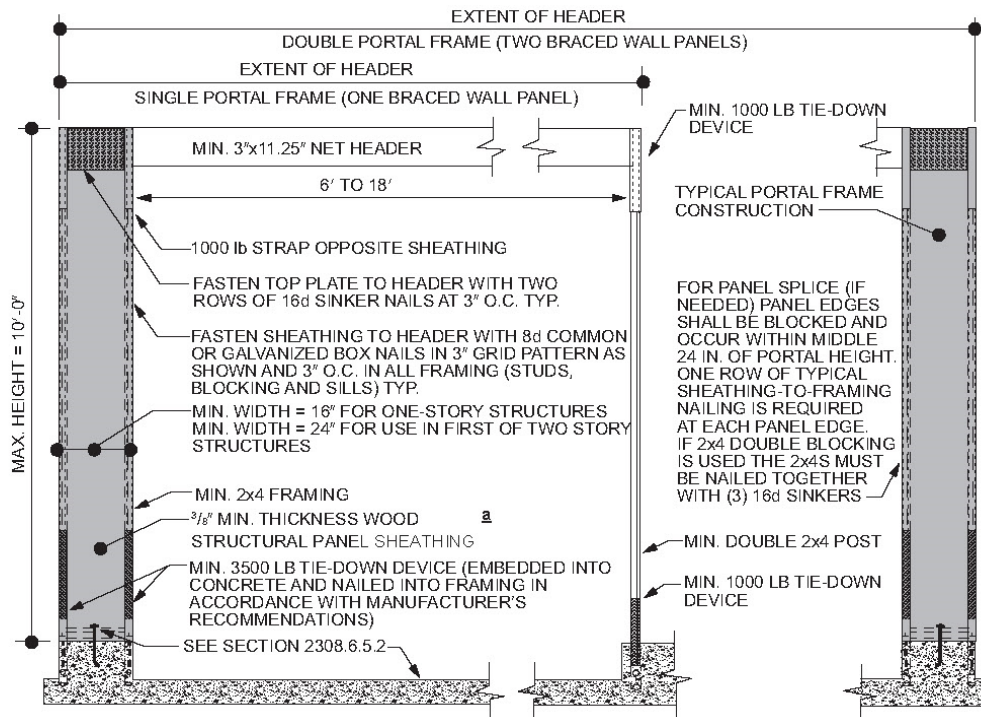

For SI: 1 inch = 25.4 mm, 1 foot = 304.8 mm, 1 pound = 4.448 N.

**a.** For structures assigned to Seismic Design Category D or E, sheathed on one face with 15/32-inch-minimum-thickness (11.9 mm) wood structural panel sheathing.

**FIGURE 2308.6.5.2  
PORTAL FRAME WITH HOLD-DOWNS (PFH)**

**18.08.130 Section 2308.6.8.1 is Amended**

Section 2308.6.8.1 is amended to read as follows:

**2308.6.8.1 Foundation requirements.** Braced wall lines shall be supported by continuous foundations. Exterior braced wall panels shall be in the same plane vertically with the foundation or the portion of the structure containing the offset shall be designed in accordance with accepted engineering practice and Section 2308.1.1.

**18.08.140 Section 2308.6.9 is Amended**

Section 2308.6.9 is amended to read as follows:

**2308.6.9 Attachment of sheathing.** Fastening of braced wall panel sheathing shall not be less than that prescribed in Table 2308.6.1 or 2304.10.1. Wall sheathing shall not be attached to framing members by adhesives. Staple fasteners in Table 2304.10.1 shall not be used to resist or transfer seismic forces in structures assigned to Seismic Design Category D, E or F.

**Exception:** Staples may be used to resist or transfer seismic forces when the allowable shear values are substantiated by cyclic testing and approved by the building official.

All braced wall panels shall extend to the roof sheathing and shall be attached to parallel roof rafters or blocking above with framing clips (18 gauge minimum) spaced at maximum 24 inches (6096 mm) on center with four 8d nails per leg (total eight 8d nails per clip). Braced wall panels shall be laterally braced at each top corner and at maximum 24 inches (6096 mm) intervals along the top plate of discontinuous vertical framing.

**Chapter 18.09**  
**AMENDMENTS TO CHAPTER 25; GYPSUM BOARD AND PLASTER, OF THE**  
**CALIFORNIA BUILDING CODE**

**Sections:**

|                  |                                    |
|------------------|------------------------------------|
| <b>18.09.005</b> | <b>Chapter 25 is Amended</b>       |
| <b>18.09.010</b> | <b>Section 2505.4 is Added</b>     |
| <b>18.09.020</b> | <b>Section 2512.1.2.1 is Added</b> |

**18.09.005 Chapter 25 is Amended**

The following sections of Chapter 25 of the California Building Code, as adopted by Chapter 18.01 hereof, are added, deleted, or amended as follows:

**18.09.010 Section 2505.4 is Added**

Section 2505.4 is added to read as follows:

**2505.4** Shear walls sheathed with gypsum board, gypsum panel products, or lath and plaster shall not be permitted as part of the primary lateral force resisting system of a building structure.

**Exception:** Shear walls sheathed with gypsum board or lath and plaster shall be permitted for conventional wood-framed structures subject to the limitations of Section 2308, as amended.

**18.09.020 Section 2512.1.2.1 is Added**

Section 2512.1.2.1 is added to read as follows:

**2512.1.2.1 Weather-resistive barrier at offset weep screeds.** Where the vertical flange of the weep screed does not align with the foundation, the gap between the weep screed and the foundation shall be protected by a continuous weather-resistive barrier that conforms to one of the following:

1. The gap between the weep screed and the foundation shall be sealed with a material approved by the Authority Having Jurisdiction; or
2. The base of the weep screed shall extend back to the foundation; or
3. Additional corrosion-resistant flashing shall be provided.

**Chapter 18.10**  
**AMENDMENTS TO APPENDIX G; FLOOD-RESISTANT CONSTRUCTION, OF THE**  
**CALIFORNIA BUILDING CODE**

**Sections:**

|                  |                                  |
|------------------|----------------------------------|
| <b>18.10.005</b> | <b>Appendix G is Amended</b>     |
| <b>18.10.010</b> | <b>Section G101.4 is Amended</b> |
| <b>18.10.020</b> | <b>Section G102.2 is Amended</b> |
| <b>18.10.030</b> | <b>Section G301.1 is Amended</b> |

**18.10.005 Appendix G is Amended**

The following sections of Appendix G of the California Building Code, as adopted by Chapter 18.01 hereof, are added, deleted, or amended as follows:

**18.10.010 Section G101.4 is Amended**

Section G101.4 is amended to read as follows:

**G101.4 Violations.** Any violation of a provision of this chapter or the City of Santa Clarita Flood Plain Ordinance, or failure to comply with a permit or variance issued pursuant to this appendix or any requirement of this appendix, shall be subject to the provisions of Section 114 of this code.

**18.10.020 Section G102.2 is Amended**

Section G102.2 is amended to read as follows:

**G102.2 Establishment of flood hazard areas.** Flood hazard areas are established as outlined in Section 1612.3 of this code.

**18.10.030 Section G301.1 is Amended**

Section G301.1 is amended to read as follows:

**G301.1 General.** Any subdivision proposal or other proposed new development in a flood hazard area shall be reviewed to assure that:

(no change to the three items listed under this section)

**Chapter 18.11**  
**AMENDMENTS TO CHAPTER 1 DIVISION II; ADMINISTRATION,**  
**OF THE CALIFORNIA RESIDENTIAL CODE**

**Sections:**

|                  |   |
|------------------|---|
| <b>18.11.005</b> | <b>Chapter 1 Division II is Amended</b>             |
| <b>18.11.010</b> | <b>Section R101.1 is Amended</b>                    |
| <b>18.11.020</b> | <b>Section R102.4.3 is Added</b>                    |
| <b>18.11.030</b> | <b>Section R102.7.1 is Amended</b>                  |
| <b>18.11.040</b> | <b>Sections R102.7.1.1 and R102.7.1.2 are Added</b> |
| <b>18.11.050</b> | <b>Section R105.2 is Amended</b>                    |
| <b>18.11.060</b> | <b>Section R105.2.2 is Amended</b>                  |
| <b>18.11.070</b> | <b>Section R106.1.4.1 is Added</b>                  |

**18.11.005 Chapter 1 Division II is Amended.**

The following sections of Chapter 1 Division II of the California Residential Code, as adopted by Chapter 18.01 hereof, are added, deleted, or amended as follows:

**18.11.010 Section R101.1 is Amended**

Section R101.1 is amended to read as follows:

**R101.1 Title.** These regulations, including all duly adopted local amendments, shall become a part of the City of Santa Clarita Building Code and may also be referred to as the Santa Clarita Residential Code for One- and Two-family Dwellings, and shall hereinafter be referred to as ‘this code’.

**18.11.020 Section R102.4.3 is Added**

Section R102.4.3 is added to read as follows:

**R102.4.3 Local Amendments.** The amendments to Chapter 1, Division II *Scope and Administration* of the California Building Code, as adopted at the local level, shall also apply to projects regulated by the California Residential Code at the local level and shall be considered part of this code.

**18.11.030 Section R102.7.1 is Amended**

Section R102.7.1 is amended to read as follows:

**R102.7.1 Additions, Alterations, or Repairs.** Additions, alterations, or repairs to any structure shall conform to the requirements for a new structure without requiring the existing structure to comply with all of the requirements of this code except as outlined in sections R102.7.1.1 and R102.7.1.2. Additions, alterations, repairs, or relocations shall not cause an existing structure to become unsafe or adversely affect the performance of the building.

**18.11.040 Sections R102.7.1.1 and R102.7.1.2 are Added**

Sections R102.7.1.1 and R102.7.1.2 are added to read as follows:

**R102.7.1.1 Substantial Improvement.** Where the proposed work includes any demolition, alteration, repair, or relocation of more than 50 percent of the existing building or component of the building, the remaining portion of the building or building component shall be upgraded to comply with the structural provisions, as well as fire and life safety provisions of this code in such cases where the Building Official determines that the existing portions of the building are substantially deficient or pose a significant hazard.

When determining the percentage of demolition, alteration, repair, or relocation, one of the following

methods shall be applied, at the discretion of the Building Official:

- a. A comparison of the square footage, lineal footage, or number of components or fixtures of the proposed demolition, alteration, repair, or relocation to the total square footage, lineal footage, or number of components or fixtures, as may be applicable.
- b. A comparison of the valuation of the proposed demolition, alteration, repair, or relocation to the valuation of the existing building.

The provisions of this section shall be cumulative over any 12 month period.

**R102.7.1.2 Substantial Addition.** Where the proposed work includes addition of new floor area that is greater than 100 percent of the existing building floor area, the existing portion of the building shall be upgraded to comply with the structural provisions, as well as fire and life safety provisions of this code in such cases where the Building Official determines that the existing portions of the building are substantially deficient or pose a significant hazard.

When determining the floor area of the existing building, the area of the garage or other unconditioned spaces shall not be included in the total area.

The provisions of this section shall be cumulative over any 12 month period.

#### **18.11.050 Section R105.2 is Amended**

Section R105.2 is amended to read as follows:

**R105.2 Work Exempted from Permit.** Exemptions from permit requirements of this code shall not be deemed to grant authorization for any work to be done in any manner in violation of the provisions of this code or any other laws or ordinances of the City of Santa Clarita including such requirements as may be established by any City department or division or the requirements of any other governing agency. Unless otherwise exempted, separate plumbing, electrical, and mechanical permits will be required for any such items not exempted herein.

For a complete list of work that is exempt from a permit refer to Section 18.02.040 of the SCMC amending 105.2 Work Exempted from Permit of the 2019 California Building Code.

#### **18.11.060 Section R105.2.2 is Amended**

Section 105.2.2 is amended to read as follows:

**105.2.2 Repairs and Maintenance.** Application or notice to the Building Official is not required for ordinary maintenance or repairs to structures. In no case shall the repair or maintenance work create an unsafe condition or violate any provision of State code. Such repairs shall not include the cutting away of any wall, partition or portion thereof, the removal or cutting of any structural beam or load-bearing support, or the removal or change of any required means of egress, or rearrangement of parts of a structure affecting the egress requirements.

For a complete list of maintenance or repairs that are exempt from a permit, refer to Section 18.02.050 of the SCMC amending 105.2.2 Repairs and Maintenance of the 2019 California Building Code.

#### **18.11.070 Section R106.1.4.1 is Added**

Section R106.1.4.1 is added to read as follows:

**R106.1.4.1 Floodplain Management.** Refer to Section 10.06 Floodplain Management of the SCMC. Where R106.1.4 and Section 10.06 Floodplain Management of the SCMC conflict, Section 10.06 Floodplain Management of the SCMC shall prevail.



**Chapter 18.12**  
**AMENDMENTS TO CHAPTER 3; BUILDING PLANNING,**  
**OF THE CALIFORNIA RESIDENTIAL CODE**

**Sections:**

|                  |                                      |
|------------------|--------------------------------------|
| <b>18.12.005</b> | <b>Chapter 3 is Amended</b>          |
| <b>18.12.010</b> | <b>Section R301.1.3.2 is Amended</b> |
| <b>18.12.020</b> | <b>Section R301.1.4 is Added</b>     |
| <b>18.12.030</b> | <b>Table R301.2(1) is Amended</b>    |
| <b>18.12.040</b> | <b>Section R301.2.2 is Amended</b>   |
| <b>18.12.050</b> | <b>Section R301.2.2.11 is Added</b>  |
| <b>18.12.060</b> | <b>Section R322.1 is Amended</b>     |
| <b>18.12.070</b> | <b>Section R322.1.5 is Amended</b>   |
| <b>18.12.080</b> | <b>Section R322.2.1 is Amended</b>   |
| <b>18.12.090</b> | <b>Section R322.2.2 is Amended</b>   |
| <b>18.12.100</b> | <b>Section R322.2.3 is Amended</b>   |
| <b>18.12.110</b> | <b>Section R322.3 is Deleted</b>     |
| <b>18.12.120</b> | <b>Section R337 is Amended</b>       |

**18.12.005 Chapter 3 is Amended.**

The following sections of Chapter 3 of the California Residential Code, as adopted by Chapter 18.01 hereof, are added, deleted, or amended as follows:

**18.12.010 Section R301.1.3.2 is Amended**

Section R301.1.3.2 is amended to read as follows:

**R301.1.3.2 Woodframe structures.** The building official shall require structural construction documents to be approved and stamped by a California licensed architect or engineer for all dwellings of woodframe construction more than one story in height or with a basement.

**18.12.020 Section R301.1.4 is Added**

Section R301.1.4 is added to read as follows:

**R301.1.4 Seismic design provisions for buildings constructed on or into slopes steeper than one unit vertical in three units horizontal (33.3 percent slope).** The structural design and construction of new buildings and additions to existing buildings when constructed on or into slopes steeper than one unit vertical in three units horizontal (33.3 percent slope) shall comply with the California Building Code.

**18.12.030 Table R301.2(1) is Amended**

Table R301.2(1) is amended as follows:

**Table R301.2(1)  
Climatic and Geographic Design Criteria**

| GROUND SNOW LOAD <sup>a</sup>               | WIND DESIGN              |                                  |                                  |                                    | SEISMIC DESIGN CATEGORY <sup>f</sup> | SUBJECT TO DAMAGE FROM     |                               |                           | WINTER DESIGN TEMP <sup>g</sup> | ICE BARRIER UNDERLAYMENT REQUIRED <sup>h</sup> | FLOOD HAZARDS <sup>g</sup>     | AIR FREEZING INDEX <sup>i</sup> | MEAN ANNUAL TEMP <sup>j</sup> |  |
|---|--------------------------|----------------------------------|----------------------------------|------------------------------------|--------------------------------------|----------------------------|-------------------------------|---------------------------|---------------------------------|--|--------------------------------|---------------------------------|-------------------------------|--|
|   | Speed <sup>d</sup> (mph) | Topographic effects <sup>k</sup> | Special wind region <sup>l</sup> | Windborne debris zone <sup>m</sup> |                                      | Weathering <sup>a</sup>    | Frost line depth <sup>b</sup> | Termite <sup>c</sup>      |                                 |  |                                |                                 |                               |  |
|   |                          |                                  |                                  |                                    |                                      |                            |                               | Moderate - Severe         |                                 |  |                                |                                 |                               |  |
| 0   | 95                       | None                             | No                               | No                                 | D2, E                                | Negligible                 | 12"                           | Moderate - Severe         | 40° F                           | No   | Note 'g'                       | 0                               | 66° F                         |  |
| <b>MANUAL J DESIGN CRITERIA<sup>n</sup></b> |                          |                                  |                                  |                                    |                                      |                            |                               |                           |                                 |  |                                |                                 |                               |  |
| Elevation                                   |                          | Latitude                         |                                  | Winter heating                     | Summer cooling                       | Altitude correction factor |                               | Indoor design temperature | Design temperature cooling      |  | Heating temperature difference |                                 |                               |  |
| 1300 ft                                     |                          | 34.4                             |                                  | Note 'p'                           | Note 'p'                             | 0.97                       |                               | 70° F, 75° F              | 91° F                           |  | 31° F                          |                                 |                               |  |
| Cooling temperature difference              |                          | Wind velocity heating            |                                  | Wind velocity cooling              | Coincident wet bulb                  | Daily range                |                               | Winter humidity           | Summer humidity                 |  | —                              |                                 |                               |  |
| 16° F                                       |                          | 15 MPH                           |                                  | 7-1/2 MPH                          | 68° F                                | H                          |                               | Note 'p'                  | Note 'p'                        |  | —                              |                                 |                               |  |

For SI: 1 pound per square foot = 0.0479 kPa, 1 mile per hour = 0.447 m/s

- a. Weathering may require a higher strength concrete or grade of masonry than necessary to satisfy the structural requirements of this code. The weathering column shall be filled in with the weathering index, “negligible,” “moderate” or “severe” for concrete as determined from Figure R301.2(3). The grade of masonry units shall be determined from ASTM C34, C55, C62, C73, C90, C129, C145, C216 or C652.
- b. The frost line depth may require deeper footings than indicated in Figure R403.1(1). The jurisdiction shall fill in the frost line depth column with the minimum depth of footing below finish grade.
- c. The jurisdiction shall fill in this part of the table to indicate the need for protection depending on whether there has been a history of local subterranean termite damage.
- d. The jurisdiction shall fill in this part of the table with the wind speed from the basic wind speed map [Figure R301.2(4)A]. Wind exposure category shall be determined on a site-specific basis in accordance with Section R301.2.1.4.
- e. Temperatures shall be permitted to reflect local climates or local weather experience as determined by the building official.
- f. The jurisdiction shall fill in this part of the table with the seismic design category determined from Section R301.2.2.1.
- g. Date of the jurisdiction’s entry into the National Flood Insurance Program: April 25, 1980. Date of the Flood Insurance Study: September 2008. Panel numbers and dates of the currently effective FIRMs and FBFMs or other flood hazard map adopted by the authority having jurisdiction, as amended: all panels for Community 060729.
- h. In accordance with Sections R905.1.2, R905.4.3.1, R905.5.3.1, R905.6.3.1, R905.7.3.1 and R905.8.3.1, where there has been a history of local damage from the effects of ice damming, the jurisdiction shall fill in this part of the table with “YES.” Otherwise, the jurisdiction shall fill in this part of the table with “NO.”
- i. The jurisdiction shall fill in this part of the table with the 100-year return period air freezing index (BF-days) from Figure R403.3(2) or from the 100-year (99 percent) value on the National Climatic Data Center data table “Air Freezing Index-USA Method (Base 32°F).”
- j. The jurisdiction shall fill in this part of the table with the mean annual temperature from the National Climatic Data Center data table “Air Freezing Index-USA Method (Base 32°F).”
- k. In accordance with Section R301.2.1.5, where there is local historical data documenting structural damage to buildings due to topographic wind speed-up effects, the jurisdiction shall fill in this part of the table with “YES.” Otherwise, the jurisdiction shall indicate “NO” in this part of the table.
- l. In accordance with Figure R301.2(4)A, where there is local historical data documenting unusual wind conditions, the jurisdiction shall fill in this part of the table with “YES” and identify any specific requirements. Otherwise, the jurisdiction shall indicate “NO” in this part of the table.
- m. In accordance with Section R301.2.1.2.1, the jurisdiction shall indicate the wind-borne debris wind zone(s). Otherwise, the jurisdiction shall indicate “NO” in this part of the table.
- n. The jurisdiction shall fill in these sections of the table to establish the design criteria using Table 1a or 1b from ACCA Manual J or established criteria determined by the jurisdiction.
- o. The jurisdiction shall fill in this section of the table using the Ground Snow Loads in Figure R301.2(6).
- p. Contact Building & Safety for information.

**18.12.040 Section R301.2.2 is Amended**

Section R301.2.2 is amended as follows:

Buildings in Seismic Design Categories C, D, and E shall be designed to resist seismic loads in accordance with the California Building Code as amended by the City of Santa Clarita. Elements of the lateral force resisting system which are designed to resist seismic loads shall comply with the provisions of the California Building Code as amended by the City of Santa Clarita.

**18.12.050 Section R301.2.2.11 is Added**

Section R301.2.2.11 is added as follows:

**R301.2.2.11 Anchorage of Mechanical, Electrical, or Plumbing Components and Equipment.**

Mechanical, electrical, or plumbing components and equipment shall be anchored to the structure in accordance with the requirements of ASCE 7 Chapter 13.

**18.12.060 Section R322.1 is Amended**

Section R322.1 is amended as follows:

**R322.1 General.** Buildings and structures constructed in whole or in part in flood hazard areas, including A Zones, as established in Table 301.2(1), and substantial improvement and restoration of substantial damage of buildings and structures in flood hazard areas, shall be designed and constructed in accordance with the provisions contained in this section and Section 10.06 Floodplain Management of the SCMC. Where this section and Section 10.06 Floodplain Management of the SCMC conflict, Section 10.06 Floodplain Management of the SCMC shall prevail. Buildings and structures that are located in more than one flood hazard area shall comply with the provisions associated with the most restrictive flood hazard area. Buildings and structures located in whole or in part in identified floodways shall be designed and constructed in accordance with ASCE 24 and Section 10.06 Floodplain Management of the SCMC. Where ASCE 24 and Section 10.06 Floodplain Management of the SCMC conflict, Section 10.06 Floodplain Management of the SCMC shall prevail.

**18.12.070 Section R322.1.5 is Amended**

Section R322.1.5 is amended as follows:

Remove “including basement” from the text.

**18.12.080 Section R322.2.1 is Amended**

Section R322.2.1 is amended as follows:

Condition 1 is amended as follows:

1. Buildings and structures in flood hazard areas shall have the lowest floors elevated to the base flood elevation plus 1 foot.

Remove “(including basement)” from the text in Condition 2.

Condition 3 is amended as follows:

3. Basement floors that are below grade on all sides shall be elevated to the base flood elevation plus 1 foot.

Exception to Condition 3 is amended as follows:

Exception: Enclosed areas below the design flood elevation shall meet the requirements of Section R322.2.2

**18.12.090 Section R322.2.2 is Amended**

Section R322.2.2 is amended as follows:

Condition 2.1.1 is added as follows:

2.1.1 The engineered opening shall be certified by the Federal Emergency Management Agency (FEMA).

**18.12.100 Section R322.2.3 is Amended**

Section R322.2.3 is amended as follows:

Remove Condition 3 under the exception.

**18.12.110 Section R322.3 is Deleted**

Section R322.3 is deleted in its entirety.

**18.12.120 Section R337 is Amended**

Section R337 is amended as follows:

Refer to Section 18.02.250 of the SCMC, added Section 118 Fire Hazard Zones ("Very High Fire Hazard Severity Zones"), for items which are added, deleted, or amended.

**Chapter 18.13**  
**AMENDMENTS TO CHAPTER 4; FOUNDATIONS,**  
**OF THE CALIFORNIA RESIDENTIAL CODE**

**Sections:**

|                  |                                      |
|------------------|--------------------------------------|
| <b>18.13.005</b> | <b>Chapter 4 is Amended</b>          |
| <b>18.13.010</b> | <b>Section R401.1 is Amended</b>     |
| <b>18.13.020</b> | <b>Section R403.1.2 is Amended</b>   |
| <b>18.13.030</b> | <b>Section R403.1.3.4 is Amended</b> |
| <b>18.13.040</b> | <b>Section R403.1.3.6 is Amended</b> |
| <b>18.13.050</b> | <b>Section R403.1.4 is Amended</b>   |
| <b>18.13.060</b> | <b>Section R403.1.5 is Amended</b>   |
| <b>18.13.070</b> | <b>Section R403.1.6.1.1 is Added</b> |
| <b>18.13.080</b> | <b>Section R403.1.6.2 is Added</b>   |
| <b>18.13.090</b> | <b>Section R404.2 is Amended</b>     |

**18.13.005 Chapter 4 is Amended.**

The following sections of Chapter 4 of the California Residential Code, as adopted by Chapter 18.01 hereof, are added, deleted, or amended as follows:

**18.13.010 Section R401.1 is Amended**

Section R401.1 is amended to read as follows:

**R401.1 Application.** The provisions of this chapter shall control the design and construction of the foundation and foundation spaces for all buildings. In addition to the provisions of this chapter, the design and construction of foundations in areas prone to flooding as established by Table R301.2(1) shall meet the provisions of Section R322. Wood foundations shall not be permitted.

**18.13.020 Section R403.1.2 is Amended**

Section R403.1.2 is amended to read as follows:

**R403.1.2 Continuous footing in Seismic Design Categories D<sub>0</sub>, D<sub>1</sub> and D<sub>2</sub>.** Exterior walls of buildings located in Seismic Design Categories D<sub>0</sub>, D<sub>1</sub> and D<sub>2</sub> shall be supported by continuous solid or fully grouted masonry or concrete footings. All required interior braced wall panels in buildings located in Seismic Design Categories D<sub>0</sub>, D<sub>1</sub> and D<sub>2</sub> shall be supported by continuous foundations.

**18.13.030 Section R403.1.3.4 is Amended**

Section R403.1.3.4 is amended to read as follows:

**R403.1.3.4 Interior bearing and braced wall panel footings in Seismic Design Categories D<sub>0</sub>, D<sub>1</sub> and D<sub>2</sub>.** Where a geotechnical report is not provided and the presence of expansive soils is unknown, the minimum depth of footings shall be 18 inches (458 mm) for interior bearing and braced walls. Such footings shall be reinforced with a minimum of two #4 rebar at the top and two #4 rebar at the bottom.

**Exception:** The minimum footing depth for unoccupied Group U structures or patio structures accessory to a Group R-3 occupancy shall be 12 inches (305 mm).

Otherwise, the minimum depth of footings below the undisturbed ground surface shall be 12 inches (305 mm).

**18.13.040 Section R403.1.3.6 is Amended**

Section R403.1.3.6 is amended to as follows:

**R403.1.3.6 Isolated concrete footings.** Isolated plain concrete footings are not permitted for exterior walls or interior braced and/or bearing walls.

**18.13.050 Section R403.1.4 is Amended**

Section R403.1.4 is amended to read as follows:

**R403.1.4 Minimum Depth.** Where a geotechnical report is not provided and the presence of expansive soils is unknown, the minimum depth of footings shall be 24 inches (610 mm) for exterior walls and 18 inches (458 mm) for interior bearing and braced walls. Such footings shall be reinforced with a minimum of two #4 rebar at the top and two #4 rebar at the bottom.

**Exception:** The minimum footing depth for unoccupied Group U structures or patio structures accessory to a Group R-3 occupancy shall be 12 inches (305 mm).

Otherwise, the minimum depth of footings below the undisturbed ground surface shall be 12 inches (305 mm). Where applicable, the depth of footings shall also conform to Section R403.1.4.1.

**18.13.060 Section R403.1.5 is Amended**

Section R403.1.5 is amended to read as follows:

**R403.1.5 Slope.** The top surface of footings shall be level. The bottom surface of footings shall be permitted to have a slope not exceeding one unit vertical in 10 units horizontal (10-percent slope). Footings shall be stepped where it is necessary to change the elevation of the top surface of the footing or where the surface of the ground slopes more than one unit vertical in 10 units horizontal (10-percent slope). Stepped footings shall be reinforced with a minimum of two #4 rebar at the top and two #4 rebar at the bottom, as shown in Figure R403.1.5.

FIGURE R403.1.5

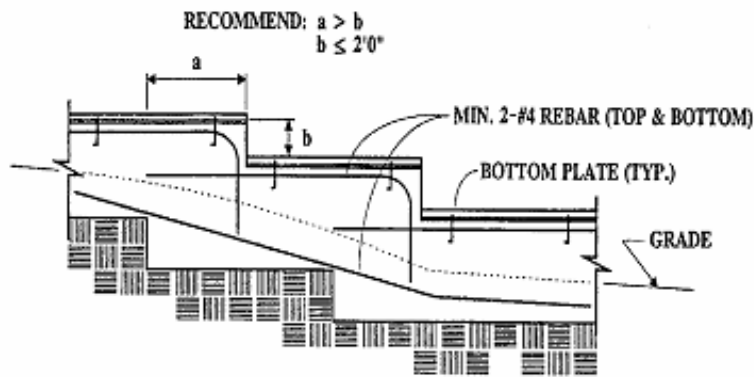

STEPPED FOUNDATIONS

**18.13.070 Section R403.1.6.1.1 is Added**

Section R403.1.6.1.1 is added as follows:

**R403.1.6.1.1 Power Actuated Fasteners.** Power actuated fasteners shall not be used to anchor sill plates or tracks except at interior non-bearing walls not designed as shear walls.

**18.13.080 Section R403.1.6.2 is Added**

Section R403.1.6.2 is added as follows:

**R403.1.6.2 Light-gage mudsill anchors.** Light-gage mudsill anchors which are intended to be bent upon installation shall not be used to anchor braced walls. Where light-gage anchors are used at exterior non-braced walls, they shall be fully protected by the exterior weather barrier assembly or by an approved corrosion-resistant coating.

**18.13.090 Section R404.2 is Amended**

Section R404.2 is amended to read as follows:

**R404.2 Wood foundation walls.** Wood foundation walls shall not be permitted.

**Chapter 18.14**  
**AMENDMENTS TO CHAPTER 5; FLOORS,**  
**OF THE CALIFORNIA RESIDENTIAL CODE**

**Sections:**

|                  |                                    |
|------------------|------------------------------------|
| <b>18.14.005</b> | <b>Chapter 5 is Amended</b>        |
| <b>18.14.010</b> | <b>Section R501.1 is Amended</b>   |
| <b>18.14.020</b> | <b>Section R503.2.4 is Added</b>   |
| <b>18.14.030</b> | <b>Figure R503.2.4 is Added</b>    |
| <b>18.14.040</b> | <b>Section R506.2.3 is Amended</b> |

**18.14.005 Chapter 5 is Amended.**

The following sections of Chapter 5 of the California Residential Code, as adopted by Chapter 18.01 hereof, are added, deleted, or amended as follows:

**18.14.010 Section R501.1 is Amended**

Section R501.1 is amended to read as follows:

**R501.1 Application.** The provisions of this chapter shall control the design and construction of the floors for all buildings including the floors of attic spaces used to house mechanical or plumbing fixtures and equipment. Mechanical or plumbing fixtures and equipment shall be attached (or anchored) to the structure in accordance with Section R301.2.2.11.

**18.14.020 Section R503.2.4 is Added**

Section R503.2.4 is added to read as follows:

**R503.2.4 Openings in horizontal diaphragms.** Openings in horizontal diaphragms with a dimension perpendicular to the joist that is greater than 4 feet (1.2 m) shall be constructed in accordance with Figure R503.2.4.



**18.14.030 Figure R503.2.4 is Added**

Figure R503.2.4 is added:

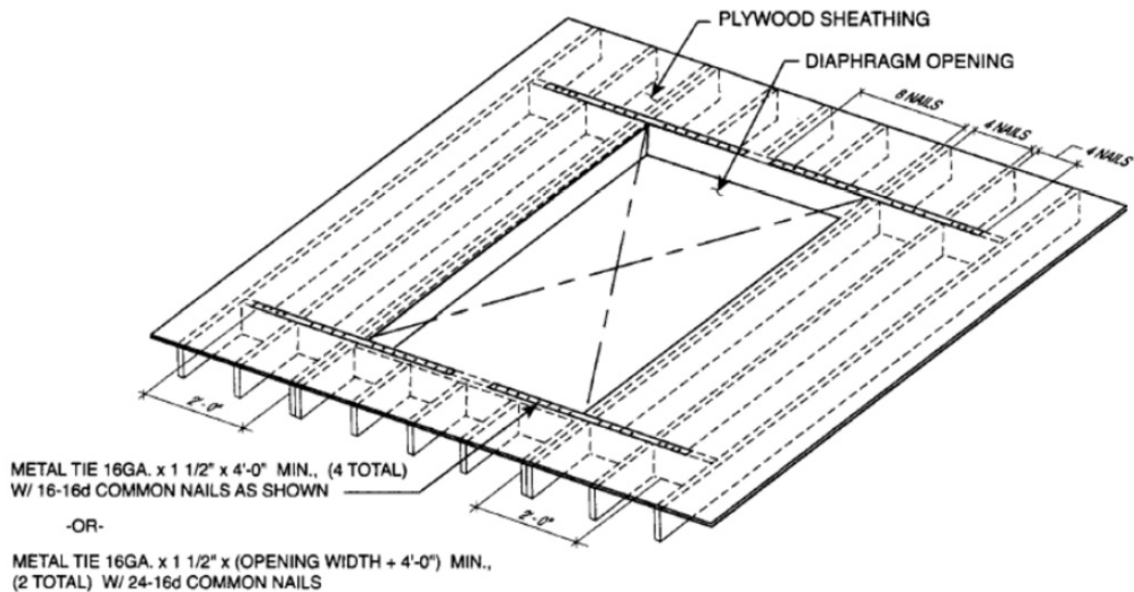

For SI: 1 inch = 25.4 mm, 1 foot = 304.8 mm.

- Blockings shall be provided beyond headers.
- Metal ties not less than 0.058 inch [1.47 mm (16 galvanized gage)] by 1.5 inches (38 mm) wide with eight 16d common nails on each side of the header-joist intersection. The metal ties shall have a minimum yield of 33,000 psi (227 MPa).
- Openings in diaphragms shall be further limited in accordance with Section R301.2.2.6.

**FIGURE R503.2.4**  
**OPENINGS IN HORIZONTAL DIAPHRAGMS**

**18.14.040 Section R506.2.3 is Amended**

Section R506.2.3 is amended to read as follows:

**R506.2.3 Vapor retarder.** One layer of 10 mil (0.010 inch) or 2-layers of 6 mil (0.006 inch) polyethylene or approved vapor retarder with joints lapped not less than 6 inches (152 mm) shall be placed between the concrete floor slab, including any ribs, and the base course or the prepared subgrade where no base course exists. Where slab ribs extend 12" or more below grade the vapor retarder need not be continuous, provided it is turned down a minimum of 6" into the footing excavation.

(no change to the exceptions listed under this section)

**Chapter 18.15**  
**AMENDMENTS TO CHAPTER 6; WALL CONSTRUCTION,**  
**OF THE CALIFORNIA RESIDENTIAL CODE**

**Sections:**

|                  |   |
|------------------|---|
| <b>18.15.005</b> | <b>Chapter 6 is Amended</b>             |
| <b>18.15.010</b> | <b>Section R602.3.2 is Amended</b>      |
| <b>18.15.020</b> | <b>Section R606.4.4 is Amended</b>      |
| <b>18.15.030</b> | <b>Section R606.12.2.2.3 is Amended</b> |

**18.15.005 Chapter 6 is Amended.**

The following sections of Chapter 6 of the California Residential Code, as adopted by Chapter 18.01 hereof, are added, deleted, or amended as follows:

**18.15.010 Section R602.3.2 is Amended**

Exception of section R602.3.2 is amended as follows:

Remove the exception to section R602.3.2.

**18.15.020 Section R606.4.4 is Amended**

Section R606.4.4 is amended to read as follows:

**R606.4.4 Parapet walls.** Masonry parapet walls shall be reinforced in accordance with Section R606.12.

**18.15.030 Section R606.12.2.2.3 is Amended**

Section R606.12.2.2.3 is amended to read as follows:

**R606.12.2.2.3 Reinforcement requirements for masonry elements.** Masonry elements listed in Section R606.12.2.2.2 shall be reinforced in either the horizontal or vertical direction as shown in Figure R606.11(3) and in accordance with the following:

1. Horizontal reinforcement. Horizontal joint reinforcement shall consist of at least one No. 4 bar spaced not more than 48 inches (1219 mm). Horizontal reinforcement shall be provided within 16 inches (406 mm) of the top and bottom of these masonry elements.
2. Vertical reinforcement. Vertical reinforcement shall consist of at least one No. 4 bar spaced not more than 48 inches (1219 mm). Vertical reinforcement shall be within 8 inches (203mm) of the ends of masonry walls.

**Chapter 18.16**  
**AMENDMENTS TO CHAPTER 8; ROOF-CEILING CONSTRUCTION,**  
**OF THE CALIFORNIA RESIDENTIAL CODE**

**Sections:**

- |                  |                                  |
|------------------|----------------------------------|
| <b>18.16.005</b> | <b>Chapter 8 is Amended</b>      |
| <b>18.16.010</b> | <b>Section R803.2.4 is Added</b> |

**18.16.005 Chapter 8 is Amended.**

The following sections of Chapter 8 of the California Residential Code, as adopted by Chapter 18.01 hereof, are added, deleted, or amended as follows:

**18.16.010 Section R803.2.4 is Added**

Section R803.2.4 is added to read as follows:

**R803.2.4 Openings in horizontal diaphragms.** Openings in horizontal diaphragms shall conform to Section R503.2.4.

**Chapter 18.17**  
**AMENDMENTS TO CHAPTER 9; ROOF ASSEMBLIES,**  
**OF THE CALIFORNIA RESIDENTIAL CODE**

**Sections:**

- |                  |                                |
|------------------|--------------------------------|
| <b>18.17.005</b> | <b>Chapter 9 is Amended</b>    |
| <b>18.17.010</b> | <b>Section R901.2 is Added</b> |

**18.17.005 Chapter 9 is Amended.**

Chapter 9 of the California Residential Code, as adopted by Chapter 18.01 hereof, is amended as follows:

**18.17.010 Section R901.2 is Added**

Section R901.2 is added to read as follows:

**901.2** Refer to Section 18.03 Amendments to Chapter 15; Roof Assemblies and Rooftop Structures of the SCMC for items which are added, deleted, or amended.

**Chapter 18.18**  
**AMENDMENTS TO CHAPTER 10; CHIMNEYS AND FIREPLACES,**  
**OF THE CALIFORNIA RESIDENTIAL CODE**

**Sections:**

- |                  |                                     |
|------------------|-------------------------------------|
| <b>18.18.005</b> | <b>Chapter 10 is Amended</b>        |
| <b>18.18.010</b> | <b>Section R1001.3.1 is Amended</b> |

**18.18.005 Chapter 10 is Amended.**

The following sections of Chapter 10 of the California Residential Code, as adopted by Chapter 18.01 hereof, are added, deleted, or amended as follows:

**18.18.010 Section R1001.3.1 is Amended**

Section R1001.3.1 is amended to read as follows:

**R1001.3.1 Vertical reinforcing.** For chimneys up to 40 inches (1016 mm) wide, four No. 4 continuous vertical bars adequately anchored into the concrete foundation shall be placed between wythes of solid masonry or within the cells of hollow unit masonry and grouted in accordance with Section R606. Grout shall be prevented from bonding with the flue liner so that the flue liner is free to move with thermal expansion. For chimneys more than 40 inches (1016 mm) wide, two additional No. 4 vertical bars adequately anchored into the concrete foundation shall be provided for each additional flue incorporated into the chimney or for each additional 40 inches (1016 mm) in width or fraction thereof.

**Title 19**

**CITY ELECTRICAL CODE**

**Chapters:**

- 19.01 Adoption of the City Electrical Code**
- 19.02 Amendments to CEC Chapter 1; General**
- 19.03 Amendments to CEC Annex H (Article 80); Administration and Enforcement**

## Chapter 19.01

### ADOPTION OF THE CITY ELECTRICAL CODE

#### Sections:

#### 19.01.010 Adoption of the City Electrical Code

#### 19.01.010 Adoption of the City Electrical Code

There is adopted by reference that certain code known and designated as the California Code of Regulations, Title 24, Part 3, further described and referred to as the 2019 California Electrical Code published by the California Building Standards Commission and based on the National Electric Code®, 2017 Edition, prepared by the National Fire Protection Association.

Adoption of said code shall include those articles, sections, and annexes requiring enforcement by the local building department and as further amended by the City of Santa Clarita with provisions intended to address local climatic, geologic, and/or topographic conditions, as permitted by State law. Adoption of said code shall include adoption of the following annexes: Annex A, *Product Safety Standards*, Annex B, *Application Information for Ampacity Calculation*, Annex C, *Tables*, Annex D, *Examples*, Annex E, *Types of Construction*, Annex F, *Critical Operations power Systems*, and Annex H, *Administration*.

Such code shall become and be the Santa Clarita Electrical Code, regulating and controlling the design, construction, installation, quality of materials, location, operation and maintenance of electrical systems, equipment and appliances. The provisions of said code shall provide for the issuance of permits and collection of fees thereof, and providing penalties for violation of such Code.

The City Electrical Code shall become effective for new permit applications received by the City on or after January 1, 2020.

At least one copy of the City Electrical Code has been deposited in the office of the City Clerk and shall be at all times maintained by the clerk for use and examination by the public.

**Chapter 19.02**  
**AMENDMENTS TO CHAPTER 1; GENERAL,**  
**OF THE CALIFORNIA ELECTRICAL CODE**

**Sections:**

**19.02.005 Chapter 1; General is Amended**

**19.02.010 Article 100 is Amended**

**19.02.005 Chapter 1; General is Amended**

The following sections of Chapter 1 of the California Electrical Code, as adopted by Chapter 19.01 hereof, are added, deleted, or amended as follows:

**19.02.010 Article 100 is Amended**

Article 100 Definitions is amended to add the following definitions and declarations:

**Grade (adjacent Ground Elevation).** The lowest point of elevation of the finished surface of the ground, paving or sidewalk within the area between the building and the property line or, when the property line is more than five feet from the building, between the building and a line five feet from the building.

**Hotel.** Any building containing six or more guest rooms intended or designed to be used, or which are used, rented or hired out to be occupied, or which are occupied for sleeping purposes by guests.



**Chapter 19.03**  
**AMENDMENTS TO ANNEX H (ARTICLE 80)**  
**OF THE CALIFORNIA ELECTRICAL CODE**

**Sections:**

|                  |   |
|------------------|---|
| <b>19.03.005</b> | <b>Annex H, Article 80, is Amended</b>                |
| <b>19.03.010</b> | <b>Section 80.7 is Deleted</b>                        |
| <b>19.03.020</b> | <b>Section 80.13 is Amended</b>                       |
| <b>19.03.030</b> | <b>Section 80.13(17) is Added</b>                     |
| <b>19.03.040</b> | <b>Section 80.15 is Amended</b>                       |
| <b>19.03.050</b> | <b>Section 80.19(A)(3) is Added</b>                   |
| <b>19.03.060</b> | <b>Section 80.19(C) is Amended</b>                    |
| <b>19.03.070</b> | <b>Section 80.19(D) is Amended</b>                    |
| <b>19.03.080</b> | <b>Section 80.19(E) is Amended</b>                    |
| <b>19.03.090</b> | <b>Section 80.21 is Amended</b>                       |
| <b>19.03.100</b> | <b>Sections 80.21(D), (E), (F), and (G) are Added</b> |
| <b>19.03.110</b> | <b>Section 80.23(B)(3) is Amended</b>                 |
| <b>19.03.120</b> | <b>Section 80.25 is Amended</b>                       |
| <b>19.03.130</b> | <b>Section 80.27 is Deleted</b>                       |
| <b>19.03.140</b> | <b>Section 80.29 is Amended</b>                       |
| <b>19.03.150</b> | <b>Section 80.35 is Deleted</b>                       |

**19.03.005 Annex H, Article 80, is Amended**

The following sections of Annex H, Article 80, of the California Electrical Code, as adopted by Chapter 19.01 hereof, are added, deleted, or amended as follows:

**19.03.010 Section 80.7 is Deleted**

Section 80.7 is deleted in its entirety.

**19.03.020 Section 80.13 is Amended**

Section 80.13 is amended to read as follows:

**80.13 Authority.** There is established within the City of Santa Clarita a division in the Public Works Department to be known as the Building & Safety Division under the administrative and operational control of the City Building Official hereinafter referred to as the Building Official. Where used in this article, the term authority having jurisdiction shall be construed to mean the Building Official or other individuals designated by the Building Official.

This Code shall be administered and enforced by the authority having jurisdiction designated by the governing body as follows.

(Provisions 1 through 16 under this section remain the same)

**19.03.030 Section 80.13(17) is Added**

Section 80.13(17) is added to read as follows:

(17) A written application shall be submitted for a proposed alternate material, method of construction or waiver together with a fee established by the City Council. The details of any action granting an alternate material or method of construction shall be noted in the files of the Building & Safety Division of the City.

**19.03.040 Section 80.15 is Amended**

Section 80.15 is amended in its entirety to read as follows:

**80.15 Electrical Board.** The electrical board shall be the Appeals Board as established under the provisions of the Santa Clarita Building Code Section 18.02.190, hereinafter designated as the Board.

**19.03.050 Section 80.19(A)(3) is Added**

Section 80.19(A)(3) is added to read as follows:

(3) The authority having jurisdiction may refuse to issue a permit for temporary or permanent service when there is no apparent legally permitted use for the service. In determining whether a proposed use is legally permitted, the authority having jurisdiction may consider not just the provisions of the Electrical Code but all applicable statutes, ordinances, rules and regulations.

**19.03.060 Section 80.19(C) is Amended**

Section 80.19(C) is amended in its entirety to read as follows:

**80.19(C) Issuance of Permits.** The authority having jurisdiction is authorized to issue a permit to the applicant for the work described in the application and plans filed therewith, when it is determined that all of the following items comply:

1. The proposed work conforms to the requirements of this code and other pertinent laws and ordinances; and any documentation necessary to demonstrate compliance has been submitted and approved by the Building Official or other individuals designated by the Building Official.
2. The required clearances from all other agencies have been obtained.
3. The appropriate fees specified by this code have been paid.

When a permit is issued and plans and/or specifications have been required to be provided, the authority having jurisdiction shall endorse in writing or stamp upon the plans and/or specifications "APPROVED." Such approved plans and specifications shall not be changed, modified or altered without authorizations from the authority having jurisdiction and the design professional of record when applicable. All work regulated by this code shall be done in accordance with the approved plans, however the approval of the plans shall not be construed as a waiver of any requirement of this code, or any other law or ordinance, unless specific documentation such as that required by Sections 80.13 (15) and (16) is provided. The issuance of a permit shall not be deemed to certify that the site of the described work is safe.

**No permit shall be required for the following electrical work:**

1. Minor repair work such as the replacement of lamps, switches, receptacle devices, sockets, taping bare joints and the like, or the connection of portable motor and appliances to suitable receptacles which have been permanently installed.
2. The temporary wiring for temporary theater, motion picture or television stage sets.
3. The repair of fixed motors, transformers, apparatus, or appliances.
4. Temporary holiday decorative lighting provided no such lighting is 'hard wired' directly into an electric panel or sub-panel.
5. The installation of temporary wiring for testing or experimental purposes within suitable facilities.
6. Repair or replacement-in-kind of overcurrent devices.

7. Portable generators, motors, appliances, tools, power outlets, and other portable equipment connected by means of a cord or cable having an attachment plug.
8. The installation by Southern California Edison Company of radio-controlled relays on privately owned air conditioning and agricultural irrigation pumping equipment in the company's pilot program of energy conservation through electrical load management, entitled "Air Conditioner Cycling and Agricultural and Pumping Interruptible Programs" provided that:
  - a. The relays shall be tested and labeled by Underwriters' Laboratories, Inc.
  - b. The Building Official shall approve of specifications for the installation of the relays.
  - c. The relays shall be installed and maintained by Southern California Edison Company or its contractors.
  - d. The Southern California Edison Company shall make available for random inspection, upon request of and by the City, designated relay installations to ensure code compliance.
9. Private telephone, intercom, sound and communication systems, data, security alarm, and television cable in single family dwellings; provided, however, that a permit shall be obtained for any added circuits supplying the power supplies required by the above systems.
10. Nonresidential communication, telephone, and data cabling systems. Nonresidential security systems may be exempted when such system is independent of the fire protection/alarm system.
11. Exemption for Utilities. The provisions of this code shall not apply to any electrical work performed by or for any electrical corporation, telephone corporation, telegraph corporation, railroad corporation or street railroad corporation on or with any electrical equipment owned or controlled and operated or used by, and for the exclusive benefit of, such corporation in the conduct of its business as a public utility, or to any other work which any such corporation shall be entitled by law to perform without payment of any local tax; but all provisions of this code shall apply insofar as they may consistently with the above be applicable to all other electrical work performed by or for any such corporation.

The terms "electrical corporation," "telephone corporation," "telegraph corporation," "railroad corporation," and "street railroad corporation," are herein used as said terms are respectively defined in the Public Utility Code of the State of California; and such terms shall also be deemed to include similar utilities which are municipally or governmentally owned and operated.

Notwithstanding the foregoing, all electrical wiring and equipment installed, altered, repaired, or replaced shall comply with the provisions of this code.

**19.03.070 Section 80.19(D) is Amended**

Section 80.19(D) is amended in its entirety to read as follows:

**(D) Owner-Builder permits.** When applying for an 'Owner-Builder' permit for an electrical installation and such installation is of a more complex nature including but not limited to any of the following:

1. Installation or modification of distribution equipment, including main service and subpanels,
2. Installation of any interconnected power production systems,
3. Installation of any circuit greater than 20 amps,

the permittee must show that the work will be performed by a 'Qualified Person' as defined in Article 100 and as demonstrated by one of the following:

1. Documentation acceptable to the authority having jurisdiction of training demonstrating the permittee or his employee possesses the skills and knowledge related to the construction and operation of the electrical equipment and/or installation as described in the permit including documentation of safety training to recognize and avoid the hazards involved. Any of the following could be considered acceptable documentation:

- a. A journeyman electrician certificate
- b. A C-10 electrical contractor's license
- c. A certificate or other documentation showing satisfactory completion of a course in electrical installation and safety training from an accredited trade school
- d. A degree in electrical engineering from an accredited college or university
- e. Completion of electrical safety training complying with NFPA 70E-2015
- f. Other documentation acceptable to the authority having jurisdiction

Exception: If competency to perform portions of the work is demonstrated to the authority having jurisdiction, the permit can be issued based on competency level, with conditions that may apply.

2. Where the permittee chooses to have the work done by a licensed electrical contractor, the name and license information of the contractor shall be provided.

#### **19.03.080 Section 80.19(E) is Amended**

Section 80.19(E) is amended in its entirety to read as follows:

##### **(E) Fees.**

**1. General.** The City shall collect such fees as are required by this code as established by the City Council and issue receipts therefor, copies of which shall be maintained as record in the office of Building & Safety.

**2. Cost of Permit.** The cost of electrical permits shall be as established by the City Council.

**3. Refund.** In the event that any person shall have obtained an electrical permit and no portion of the work covered by such permit has been commenced and such permit shall have been canceled and a written request for cancellation, having been approved by the authority having jurisdiction, the applicant/permittee may request a refund from the City for a maximum of eighty (80) percent of the permit fees paid excluding issuance fees or plan review fees.

The applicant shall present all necessary documentation including the original signed permit and inspection record card to the authority having jurisdiction showing they are entitled to receive such refund of the permit fee as described above. No refunds shall be granted more than 90 days after the date the permit or application for permit has expired, become inactive, been cancelled, or passed a final inspection. No refund shall be made for a permit which was obtained by falsification or misrepresentation and which was subsequently revoked for such cause.

**4. Work without a Permit.** Whenever any work for which a permit is required by this code has been commenced without first obtaining said permit, a special investigation shall be made before a permit may be issued for such work. An investigation fee shall be collected whether or not a permit is then or subsequently issued. The investigation fee shall be twice the amount of the permit fee required by this code and shall be in addition to any fees for permits issued in connection with the work investigated. The payment of such investigation fee shall not exempt any person from compliance with all other provisions of this code nor from any penalty prescribed by law.

#### **19.03.090 Section 80.21 is Amended**

Section 80.21 is amended to read as follows:

**80.21 Plans Review.** Review of plans and specifications, submittal document requirements, plan review fees, and expiration of plan review shall conform to (A) through (G).

**19.03.100 Sections 80.21(D), (E), (F), and (G) are Added**

Sections 80.21(D), (E), (F), and (G) are added to read as follows:

**(D) Submittal Documents.** The authority having jurisdiction shall require the submission of plans, specifications, drawings, descriptions and diagrams as appropriate to clearly show the character, kind, and extent of electrical work covered by an application for a permit. Such documents may be submitted in electronic format upon approval of the authority having jurisdiction.

**Exception:** If in the opinion of the authority having jurisdiction the scope of work is determined to be of a minor nature, the submittal of such documents may be waived by the authority having jurisdiction.

**(E) Information Required on Plans.**

1. Every plan required by section (D) of this section shall be a print or other type approved by the Building & Safety Division. Electronic media documents may be submitted as determined by the Building Official. The information contained on the plans shall be drawn in a professional manner, be clearly legible and contain the information required in section (E)(2) of this section. Labeling, lettering, dimensioning, and numbering shall be of a size and style to be easily read and shall be in conformance with accepted professional practices and standards for architectural and engineering documents. Reasonable symbols satisfactory to the Division shall be used in all plans. Submitted plans and specifications, which are deemed incomplete or incorrect, shall be returned to the architect or registered engineer or other individual in general responsible charge with a request for compliance with these regulations before checking is begun or resumed by Building & Safety Division staff.

2. The following is required to be shown on the plans for all electrical installations requiring a permit:

- a. A complete single-line diagram;
- b. The type, location, and capacity of all service equipment;
- c. The size and length of all feeder raceways;
- d. The dimensions of all pull or junction boxes larger than four (4) inches trade size;
- e. The number, size, and type of all conductors to be installed in each feeder circuit;
- f. The location of every proposed outlet and switch in all parts of the building or structure, including all fixed showcases, wall-cases, office furnishings, and similar wiring and the location of all existing circuits and outlets within or related to the areas of new or modified electrical installations;
- g. The location, voltage and HP rating of every motor that is not a component of a listed appliance and the KW rating of every generator;
- h. The location and KVA or equivalent rating of each transformer and similar equipment; and the location and ampere or wattage rating of other appliances of the noninductive type;
- i. Details of panelboard, switchboard and motor control center schedules, showing wattage and amperage, of active branch circuits to be installed or modified, and the number of spare branch circuits for future use. This shall include identifying the circuits to which the outlets are connected and listing the number and type of outlets;
- j. A lighting fixture schedule;

- k. The existing load, as calculated in accordance with Articles 210 and 220 of the NEC or by other methods satisfactory to the authority having jurisdiction shall be indicated for existing installations, alterations, or additions made thereto;
- l. Other additional information as the authority having jurisdiction may consider necessary for proper enforcement of this code.

**Exception (1):** R-3 and U occupancies that are accessory to R-3. Information required is limited to the location of all electrical outlets, including, but not limited to receptacles, switches, lighting, power for appliances, disconnecting means for appliances, and the location and size of the electrical service and any sub-panel(s). Alternative power source systems and specialized electrical installations may require more information on the plans.

**Exception (2):** Some or all plan requirements may be waived at the discretion of the authority having jurisdiction for work considered to be of a minor nature.

**(F) Plan Review Fees.** Plan review fees shall be paid in full when the plans are submitted for review. The cost of the electrical plan review shall be as established by the City Council.

**(G) Expiration of Plan Review.** Applications for which no electrical permit has been issued within twelve months days following the date of application, shall expire by limitation, and plans and other data submitted for review may thereafter be returned to the applicant or destroyed by the authority having jurisdiction. The authority having jurisdiction may extend the time for action by the applicant for a period not exceeding one hundred eighty (180) days on request by the applicant which includes sufficient justification for the extension. The authority having jurisdiction may collect a fee for any application for extension of plan review in accordance with the City's fee schedule. No application shall be extended more than twice. In order to renew action on an application after expiration, the applicant shall resubmit plans and pay a new plan review fee.

#### **19.03.110 Section 80.23(B)(3) is Amended**

Section 80.23(B)(3) is amended to read as follows:

(3) Any person, firm, or corporation who violates any of the provisions of this code is guilty of a misdemeanor punishable by a fine not exceeding one thousand dollars (\$1,000) or by imprisonment not exceeding six (6) months, or by both such fine and imprisonment, (see Section 17995 of the State Health and Safety Code), unless such violation is otherwise declared to be an infraction by the City Council. Such person shall be guilty of a separate offense for each and every day or portion thereof during which any violation of any of the provisions of this code is committed, continued, or permitted to remain.

#### **19.03.120 Section 80.25 is Amended**

Section 80.25 is amended to read as follows:

**80.25 Connection to Electricity Supply.** Connection to the electric supply shall conform to (A) through (D).

**(A) Authorization.** Except as provided in 80.25, it shall be unlawful for any person, firm, or corporation to make connection to a supply of electricity or to supply electricity to any electric equipment installation for which a permit is required or that has been disconnected or ordered to be disconnected.

**(B) Special Consideration.** By special permission of the authority having jurisdiction, temporary power shall be permitted to be supplied to the premises for specific needs of the construction project.

**(C) Disconnection.** The authority having jurisdiction is empowered to disconnect or to order in writing the discontinuance of electrical service to wiring, devices or materials found to be dangerous and a hazard to life, health and property until the installation of such wiring, device or material has been made safe as directed by the authority having jurisdiction.

Any person, firm, corporation, public utility, political subdivision or governmental agency ordered to discontinue such electrical service shall do so within twenty-four (24) hours after the receipt of such written notice and shall not reconnect such service or allow or cause the same to be reconnected until notified to do so by the authority having jurisdiction.

**(D) Service upgrades.** Prior to the replacement of any electrical service, the licensed electrical contractor shall contact the local Utility Planning Department for guidance and shall proceed as directed by the Utility. Electrical supply lines shall not be reconnected to the service equipment until the installation has been inspected by the authority having jurisdiction or an authorized representative of the Building Official. Under no circumstances shall a representative of the City of Santa Clarita inspect a service with exposed, energized components.

**19.03.130 Section 80.27 is Deleted**

Section 80.27 is deleted in its entirety.

**19.03.140 Section 80.29 is Amended**

Section 80.29 is amended to read as follows:

**80.29 Liability for Damages.** Article 80 shall not be construed to affect the responsibility or liability of any party owning, designing, operating, controlling, or installing any electrical equipment for damages to persons or property caused by a defect therein, nor shall the City of Santa Clarita or any of its employees be held as assuming any such liability by reason of the inspection, re-inspection, or other examination authorized.

**19.03.150 Section 80.35 is Deleted**

Section 80.35 is deleted in its entirety.

## **Title 20**

### **CITY PLUMBING CODE**

#### **Chapters:**

- 20.01 Adoption of the City Plumbing Code**
- 20.02 Amendments to CPC Chapter 1 Division II; Administration**
- 20.03 Amendments to CPC Chapter 3; General Regulations**
- 20.04 Amendments to CPC Chapter 7; Sanitary Drainage**



**Chapter 20.01**  
**ADOPTION OF THE CITY PLUMBING CODE**

**Sections:**

**20.01.010 Adoption of the City Plumbing Code**

**20.01.010 Adoption of the City Plumbing Code**

There is hereby adopted by reference that certain code known and designated as the California Code of Regulations, Title 24, Part 5, further described and referred to as the 2019 California Plumbing Code published by the California Building Standards Commission and based on the Uniform Plumbing Code®, 2018 Edition, prepared by the International Association of Plumbing and Mechanical Officials.

The adoption of said code shall include those sections requiring enforcement by the local building department as mandated by the State and as further amended by the City of Santa Clarita with provisions intended to address local climatic, geologic, and topographic conditions, as permitted by State law. Adoption of said code shall include the adoption of the following appendices: Appendix A, Appendix B, Appendix D, Appendix G, and Appendix I.

Such code shall become and be the Santa Clarita Plumbing Code, regulating plumbing and drainage systems, house sewers, private sewage disposal, drainage systems, and prescribing conditions under which such work may be carried on within the City and providing for the issuance of permits and the collection of fees therefore.

The City Plumbing Code shall become effective for new permit applications received by the City on or after January 1, 2020.

At least one copy of the City Plumbing Code has been deposited in the office of the City Clerk and shall be at all times maintained by the Clerk for use and examination by the public.

**Chapter 20.02**  
**AMENDMENTS TO CHAPTER 1, DIVISION II OF THE**  
**CALIFORNIA PLUMBING CODE**

**Sections:**

|                  |   |
|------------------|---|
| <b>20.02.005</b> | <b>Chapter 1 Division II is Amended</b> |
| <b>20.02.010</b> | <b>Section 101.1 is Amended</b>         |
| <b>20.02.020</b> | <b>Section 101.6 is Added</b>           |
| <b>20.02.030</b> | <b>Section 103.1 is Amended</b>         |
| <b>20.02.040</b> | <b>Section 104.3.2 is Amended</b>       |
| <b>20.02.050</b> | <b>Section 104.5 is Amended</b>         |
| <b>20.02.060</b> | <b>Section 104.5.2 is Amended</b>       |
| <b>20.02.070</b> | <b>Section 104.5.3 is Amended</b>       |
| <b>20.02.080</b> | <b>Section 107.1.1 is Amended</b>       |

**20.02.005 Chapter 1 Division II is amended.**

The following sections of Chapter 1, Division II of the California Plumbing Code, as adopted by Section 20.01 hereof, are added, deleted, or amended as follows:

**20.02.010 Section 101.1 is Amended**

Section 101.1 is amended to read as follows:

**101.1 Title** These regulations shall be known as the Santa Clarita Plumbing Code and shall be used in conjunction with the provisions of Title 24, California Code of Regulations, mandated by the State of California to be enforced by the local building department, all of which may be cited herein as "this code."

**20.02.020 Section 101.6 is Added**

Section 101.6 is added to read as follows:

**101.6 Work in Public Right-of-Way.** No person shall install, remove, alter, or repair any sewer or part thereof which is located in any public way within the City of Santa Clarita without having first obtained all required approvals and permits from each agency which has jurisdiction over the particular thoroughfare or utility affected. Such agencies may include but are not limited to: City Engineering Services, L.A. County Sanitation District, L.A. County Sewer Maintenance District, and the State Department of Transportation (CALTRANS).

**20.02.030 Section 103.1 is Amended**

Section 103.1 is amended to read as follows:

**103.1 Authority Having Jurisdiction.** There is established within the City of Santa Clarita, a division in the Public Works Department known as the Building & Safety Division under the administrative and operational control of the City Building Official. The City Building Official is designated as the Authority Having Jurisdiction duly appointed to enforce this code.

Whenever the term "Authority Having Jurisdiction" or "Building Official" is used in any section of this code such term shall be construed to mean the City Building Official of the City of Santa Clarita.

The Authority Having Jurisdiction shall be the authority duly appointed to enforce this code. The Authority Having Jurisdiction shall have the power to render interpretations of this code and to adopt

enforce rules and regulations to supplement to this code as deemed necessary in order to clarify the applications of the provisions of this code. Such interpretations, rules, and regulations shall comply with intent and purpose of this code.

The Building Official is authorized and directed to enforce all of the provisions of this code and to make inspections pursuant to the provisions of this code. For such purposes the Building Official shall have the powers of a law enforcement officer.

The Building Official shall have the power to render interpretations of this code and to adopt and enforce rules and regulations supplemental to this code as may be deemed necessary in order to clarify the application of the provisions of this code. Such interpretations, rules, and regulations shall be in conformity with the intent and purpose of this code.

**20.02.040 Section 104.3.2 is Amended**

Section 104.3.2 is amended to read as follows:

**104.3.2 Plan Review Fees.** When plans or other data are required to be submitted by Section 104.3.1, a plan review fee shall be paid at the time of submitting plans and specifications for review.

The plan review fees for plumbing work shall be as set forth and adopted by the City Council.

The plan review fees specified in this section are separate fees from the permit fees specified in this section and are in addition to the permit fees.

When plans are incomplete or changed so as to require additional review, an additional plan review fee shall be charged in accordance with the fees adopted by the City Council.

**20.02.050 Section 104.5 is Amended**

Section 104.5 is amended to read as follows:

**104.5 Permit Fees.** The fee for each permit shall be as set forth and adopted by the City Council.

**20.02.060 Section 104.5.2 is Amended**

Section 104.5.2 is amended to read as follows:

**104.5.2 Investigation Fee.** An investigation fee, in addition to the permit fee, shall be collected whether or not a permit is then or subsequently issued. The investigation fee shall be equal to twice the amount of the permit fee that would be required by this code if a permit were to be issued and shall be in addition to any fees for permits issued in connection with the work investigated. The minimum investigation fee shall be as established by the City Council. The payment of such investigation fee shall not exempt any person from compliance with all other provisions of this code, nor from any penalty prescribed by law.

**20.02.070 Section 104.5.3 is Amended**

Section 104.5.3 is amended to read as follows:

**104.5.3 Fee Refunds.** The Building Official may authorize the refunding of not more than 80 percent of any fee paid hereunder, excluding issuance fees or plan review fees, when no work has been done under a permit issued in accordance with this code. No refund shall be authorized except on written application filed by the original applicant or permittee not later than 90 days after the date the permit or application for permit has expired, become inactive, been cancelled, or passed a final inspection.

**20.02.080 Section 107.1.1 is Added**

Section 107.1.1 is added to read as follows:

**107.1.1 Appeals.** Appeals of determinations made by the Building Official for this code shall be made in accordance with Chapter 18.02 Section 18.02.190 of Title 18, City Building Code.

**Chapter 20.03**  
**AMENDMENTS TO CHAPTER 3 OF THE CALIFORNIA PLUMBING CODE**

**Sections:**

|                  |                                 |
|------------------|---------------------------------|
| <b>20.03.005</b> | <b>Chapter 3 is Amended</b>     |
| <b>20.03.010</b> | <b>Section 301.2.6 is Added</b> |

**20.03.005 Chapter 3 is Amended**

The following sections of Chapter 3 of the California Plumbing Code, as adopted by Section 20.01 hereof, are added, deleted, or amended as follows:

**20.03.010 Section 301.2.6 is Added**

Section 301.2.6 is added to read as follows:

**301.2.6 Used Materials.** Previously used industrial apparatus and processing equipment may be reinstalled provided it complies with all applicable provisions of this code.

## Chapter 20.04

### AMENDMENTS TO CHAPTER 7 OF THE CALIFORNIA PLUMBING CODE

#### Sections:

|                  |                               |
|------------------|-------------------------------|
| <b>20.04.005</b> | <b>Chapter 7 is Amended</b>   |
| <b>20.04.010</b> | <b>Section 714.6 is Added</b> |
| <b>20.04.020</b> | <b>Section 714.7 is Added</b> |

#### **20.04.005 Chapter 7 is Amended**

The following sections of Chapter 7 of the California Plumbing Code, as adopted by Section 20.01 hereof, are added, deleted, or amended as follows:

#### **20.04.010 Section 714.6 is Added.**

Section 714.6 is added to read as follows:

**714.6** Water softener systems using dry wells for the discharge of effluents are prohibited in the City of Santa Clarita.

**Exception:** Systems with regeneration cycles discharging quantities of total dissolved solids that do not exceed those stipulated in the water quality objectives set by the Regional Water Quality Control Board when approved by the Building Official.

#### **20.04.020 Section 714.7 is Added.**

Section 714.7 is added to read as follows:

**714.7** Automatic or self-regenerating water softener systems using sodium chloride (salt) or potassium chloride are prohibited in the City of Santa Clarita.

**Exception:** Commercially installed water softener systems that utilize portable exchange tanks maintained by a commercially licensed company where no brine waste is discharged into the public sewer system.

## **Title 21**

### **CITY MECHANICAL CODE**

#### **Chapters:**

- 21.01 Adoption of City Mechanical Code**
- 21.02 Amendments to Chapter 1 Division II, Administration**
- 21.03 Amendments to Chapter 3, General Regulations**

## **Chapter 21.01**

### **ADOPTION OF THE CITY MECHANICAL CODE**

#### **Sections:**

#### **21.01.010 Adoption of the City Mechanical Code**

##### **21.01.010 Adoption of the City Mechanical Code.**

There is hereby adopted by reference that certain code known and designated as the California Code of Regulations, Title 24, Part 4, further described and referred to as the 2019 California Mechanical Code published by the California Building Standards Commission and based on the Uniform Mechanical Code®, 2018 Edition, prepared by the International Association of Plumbing and Mechanical Officials.

The adoption of said code shall include those sections requiring enforcement by the local building department and as further amended by the City of Santa Clarita with provisions intended to address local climatic, geologic, and topographic conditions, as permitted by State law. Adoption of said code shall include the adoption of the following appendices: Appendix D, Appendix F, and Appendix G.

Such code shall become and be the Santa Clarita Mechanical Code, regulating heating, ventilating, comfort cooling, refrigeration systems and other miscellaneous heating appliances, prescribing conditions under which such work may be performed within the City and providing for the issuance of permits and the collection of fees therefore.

The City Mechanical Code shall become effective for new permit applications received by the City on or after January 1, 2020.

At least one copy of the City Mechanical Code has been deposited in the office of the City Clerk and shall be at all times maintained by the Clerk for use and examination by the public.



**Chapter 21.02**  
**AMENDMENTS TO CHAPTER 1 DIVISION II OF THE**  
**CALIFORNIA MECHANICAL CODE**

**Sections:**

|                  |   |
|------------------|---|
| <b>21.02.005</b> | <b>Chapter 1 Division II is Amended</b> |
| <b>21.02.010</b> | <b>Section 101.0 is Amended</b>         |
| <b>21.02.020</b> | <b>Section 103.1 is Amended</b>         |
| <b>21.02.030</b> | <b>Section 104.3.2 is Amended</b>       |
| <b>21.02.040</b> | <b>Section 104.5 is Amended</b>         |
| <b>21.02.050</b> | <b>Section 104.5.2 is Amended</b>       |
| <b>21.02.060</b> | <b>Section 104.5.3 is Amended</b>       |

**21.02.005 Chapter 1 Division II is Amended.**

The following sections of Chapter 1 Division II of the California Mechanical Code, as adopted by Chapter 21.01 hereof, are added, deleted, or amended as follows:

**21.02.010 Section 101.0 is Amended**

Section 101.0 is amended to read as follows:

**101.0 Title.** These regulations shall be known as the Santa Clarita Mechanical Code and shall be used in conjunction with the provisions of Title 24, California Code of Regulations, mandated by the State of California to be enforced by the local building department, all of which may be cited herein as "this code."

**21.02.020 Section 103.1 is Amended**

Section 103.1 is amended to read as follows:

**103.1 General.** There is established within the City of Santa Clarita, a division in the Public Works Department known as the Building & Safety Division under the administrative and operational control of the City Building Official. The City Building Official is designated as the Authority Having Jurisdiction duly appointed to enforce this code.

Whenever the term "Authority Having Jurisdiction" or "Building Official" is used in any section of this code such term shall be construed to mean the City Building Official of the City of Santa Clarita.

The Authority Having Jurisdiction shall be the Authority duly appointed to enforce this code. The Authority Having Jurisdiction shall have the power to render interpretations of this code and to adopt enforce rules and regulations to supplement to this code as deemed necessary in order to clarify the applications of the provisions of this code. Such interpretations, rules, and regulations shall comply with intent and purpose of this code.

The Building Official is authorized and directed to enforce all of the provisions of this code and to make inspections pursuant to the provisions of this code. For such purposes the Building Official shall have the powers of a law enforcement officer.

The Building Official shall have the power to render interpretations of this code and to adopt and enforce rules and regulations supplemental to this code as may be deemed necessary in order to clarify the application of the provisions of this code. Such interpretations, rules, and regulations shall be in conformity with the intent and purpose of this code.

**21.02.030 Section 104.3.2 is Amended**

Section 104.3.2 is amended as follows:

**104.3.2 Plan Review Fees.** When plans or other data are required to be submitted by Section 104.3.1, a plan review fee shall be paid at the time of submitting plans and specifications for review. The plan review fees for mechanical work shall be as set forth and adopted by the City Council.

The plan review fees specified in this section are separate fees from the permit fees specified in section 104.5 and are in addition to the permit fees.

When plans are incomplete or changed so as to require additional plan review, an additional plan review fee shall be charged at the rate adopted by the City Council.

**21.02.040 Section 104.5 is Amended**

Section 104.5 is amended as follows:

**104.5 Permit Fees.** The fee for each permit shall be as set forth and adopted by the City Council.

**21.02.050 Section 104.5.2 is Amended**

Section 104.5.2 is amended to read as follows:

**104.5.2 Investigation Fee.** An investigation fee, in addition to the permit fee, shall be collected whether or not a permit is then or subsequently issued. The investigation fee shall be equal to twice the amount of the permit fee that would be required by this code if a permit were to be issued and shall be in addition to any fees for permits issued in connection with the work investigated. The minimum investigation fee shall be as established by the City Council. The payment of such investigation fee shall not exempt any person from compliance with all other provisions of this code, nor from any penalty prescribed by law.

**21.02.060 Section 104.5.3 is Amended**

Section 104.5.3 is amended to read as follows:

**104.5.3 Fee Refunds.** The Building Official may authorize the refunding of a fee as follows:

1. Not more than 80 percent of the permit fee, excluding issuance fees or plan review fees, paid hereunder when no work has been done under a permit issued in accordance with this code.
2. Not more than 80 percent of the plan review fee paid hereunder, when an application for a permit for which a plan review fee has been paid is withdrawn or canceled before any plan review effort has been expended.

The Building Official shall not authorize refunding of any fee paid except upon written application filed by the original permittee or applicant not exceeding 90 days from date the permit or application for permit expired, became inactive, been cancelled, or passed a final inspection.

**Chapter 21.03**  
**AMENDMENTS TO CHAPTER 3; GENERAL REGULATIONS, OF THE**  
**CALIFORNIA MECHANICAL CODE**

**Sections:**

**21.03.005 Chapter 3 is Amended**  
**21.03.010 Section 302.2 is Amended**

**21.03.005 Chapter 3 is Amended**

The following sections of Chapter 3 of the California Mechanical Code, as adopted by Chapter 21.01 hereof, are added, deleted, or amended as follows:

**21.03.010 Section 302.2 is Amended**

Section 302.2 is amended to read as follows:

**302.2 Alternate Materials and Methods of Construction Equivalency.** Nothing in this code is intended to prevent the use of any material, appliance, installation, device, arrangement, or method of construction not specifically prescribed, provided any such alternate has been approved by the Building Official.

The Building Official may approve any such alternate, provided, it is determined that the proposed design is satisfactory and complies with the technical provisions of this code, and that the material, method or work offered is, for the purpose intended, at least the equivalent of that prescribed in this code in suitability, strength, effectiveness, fire resistance, durability, and safety.

Such approval shall be based upon submittal of substantiating data and including, but not limited to, performance characteristics, measurements, calculations, diagrams, equipment and construction factors, where applicable.

A written application shall be submitted for a proposed alternate material or method of construction together with a fee established by the City Council. The details of any action granting an alternate material or method of construction shall be noted in the files of the Building & Safety Division of the City.

**Title 22**

**CITY FIRE CODE**

**Chapters:**

**22.01      Adoption of the City Fire Code**

## **Chapter 22.01**

### **ADOPTION OF THE CITY FIRE CODE**

#### **Sections:**

#### **22.01.010 Adoption of the City Fire Code**

#### **22.01.010 Adoption of the City Fire Code**

There is hereby adopted by reference that certain code known and designated as the California Code of Regulations, Title 24, Part 9, further described and referred to as the 2019 California Fire Code published by the California Building Standards Commission and based on the International Fire Code®, 2018 Edition, prepared by the International Code Council.

Adoption of said code shall include such amendments to the 2019 California Fire Code as duly adopted by the County of Los Angeles and referred to as Title 32 of the Los Angeles County Code, also known as the County of Los Angeles Fire Code.

Such code shall become and be the Santa Clarita Fire Code, regulating and governing the safeguarding of life and property from fire and explosion hazards arising from the storage, handling and use of hazardous substances, materials and devices, and from conditions hazardous to life or property in the occupancy of buildings and premises in the City of Santa Clarita.

The Santa Clarita Fire Code shall become effective January 1, 2020.

At least one copy of the Santa Clarita Fire Code has been deposited in the office of the City Clerk, and shall be at all times maintained by the Clerk for use and examination by the public.

## **Title 24**

### **CITY ENERGY CONSERVATION CODE**

#### **Chapters:**

**24.01      Adoption of the City Energy Conservation Code**

## **Chapter 24.01**

### **ADOPTION OF THE CITY ENERGY CONSERVATION CODE**

#### **Sections:**

#### **24.01.010 Adoption of the City Energy Conservation Code**

#### **24.01.010 Adoption of the City Energy Conservation Code**

There is hereby adopted by reference that certain code known and designated as California Code of Regulations, Title 24, Part 6, further described and referred to as the 2019 California Energy Code, published by the California Building Standards Commission.

Such Code shall become and be the City of Santa Clarita Energy Conservation Code, regulating the design, construction, alteration, installation, or repair of building envelopes, space-conditioning systems, water-heating systems, indoor lighting systems of buildings, outdoor lighting and signage, and certain equipment to enhance the efficiency and reduce energy use of such buildings as specifically provided for therein.

The City of Santa Clarita Energy Conservation Code shall become effective for new building permit applications received by the City on or after January 1, 2020.

At least one copy of the City of Santa Clarita Energy Conservation Code shall be maintained and kept available for reference and examination by the public at the City's Permit Center public counter.

**Title 25, Chapter 25.01**

**CITY GREEN BUILDING STANDARDS CODE**

**Chapters:**

**25.01      Adoption of the City Green Building Standards Code**



**Chapter 25.01**  
**ADOPTION OF THE CITY GREEN BUILDING STANDARDS CODE**

**Sections:**

**25.01.010          Adoption of the City Green Building Standards Code**

**25.01.010 Adoption of the City Green Building Standards Code**

There is hereby adopted by reference that certain code known and designated as the California Code of Regulations, Title 24, Part 11, further described as the 2019 California Green Building Standards Code, also referred to as the 2019 CalGreen Code, published by the California Building Standards Commission.

Such Code shall become and be the City of Santa Clarita Green Building Standards Code, regulating the planning, design, operation, construction, use and occupancy of every new building or structure to ensure buildings have a more positive environmental impact and encourage sustainable construction practices as specifically provided for therein.

The City of Santa Clarita Green Building Standards Code shall become effective for new building permit applications received by the City on or after January 1, 2020.

At least one copy of the City of Santa Clarita Green Building Standards Code shall be maintained and kept available for reference and examination by the public at the City's Permit Center public counter.