



City of
SANTA CLARITA

23920 Valencia Boulevard • Suite 300 • Santa Clarita, California 91355-2196
Phone: (661) 259-2489 • FAX: (661) 259-8125
www.santa-clarita.com

**CITY OF SANTA CLARITA
MASTER CASE NO. 15-183
SIGN REVIEW 15-019
PER CODE SECTION 17.23.190**

Date: November 6, 2015

Applicant: Darcey Oldhafer
Golden Road Partners, LLC
28388 Constellation Road, Suite 900
Santa Clarita, CA 91355

Request: The applicant is requesting approval of a sign review permit for Enhanced Signage and a Master Sign Program for a new shopping center located at 19915 Golden Valley Road (Assessor Parcel Number 2842-036-067). The Sign program would allow one wall sign per tenant for each elevation (parking lot and street side), along with two (2) monument signs: one at the shopping center entrance on Golden Valley Road and the other at the entrance on Sierra Highway.

Findings: In granting this approval, the Director of Community Development finds that the required Burden of Proof set forth in Section 17.23.190 of the Santa Clarita Municipal Code has been met by the applicant. The Director further finds that the use is categorically exempt since it meets the criteria set forth in Class 11 of Section 15311(a) of the California Environmental Quality Act Guidelines. This approval is granted pursuant to the following conditions.

CONDITIONS OF APPROVAL

GENERAL

- GC1. The approval of this project shall be utilized within two (2) years from the date of conditional approval, unless it is extended in accordance with the terms and provisions of the City of Santa Clarita's Unified Development Code.
- GC2. To the extent the use approved with this project is a different use than previously approved for the property, the prior approval shall be terminated along with any



associated vested rights to such use, unless such prior approved use is still in operation, or is still within the initial pre-commencement approval period. Once commenced, any discontinuation of the use approved with this project for a continuous period of one hundred eighty (180) calendar days or more shall terminate the approval of this use along with any associated vested rights to such use. The pre-existing legal use shall not be re-established or resumed after the one hundred eighty (180) day period. Discontinuation shall include cessation of a use regardless of intent to resume.

- GC3. The applicant may file for an extension of the conditionally approved project prior to the date of expiration. If such an extension is requested, it must be filed no later than 60 days prior to expiration.
- GC4. The applicant shall be responsible for notifying the Director of Community Development, in writing, of any change in ownership, designation of a new engineer, or change in the status of the developer, within 30 days of said change.
- GC5. Unless otherwise apparent from the context, the term "applicant" shall include the applicant and any other persons, corporation, or other entity making use of this grant. The applicant shall defend, indemnify, and hold harmless the City of Santa Clarita, its agents, officers, and employees from any claim, action, or proceeding against the City or its agents, officers, or employees to attack, set aside, void, or annul the approval of this project, including any related environmental approvals. In the event the City becomes aware of any such claim, action, or proceeding, the City shall promptly notify the applicant, or if the city fails to cooperate fully in the defense, the applicant shall not thereafter be responsible to defend, indemnify, or hold harmless the City. Nothing contained in this Condition prohibits the City from participating in the defense of any claim, action, or proceeding, if both the following occur: 1) the City bears its own attorney's fees and costs; and 2) the City defends the action in good faith. The applicant shall not be required to pay or perform any settlement unless the settlement is approved by the applicant.
- GC6. The property shall be developed and maintained in substantial conformance with the approvals granted by the City. Any modifications shall be subject to further review by the City.
- GC7. The applicant shall comply with all inspection requirements as deemed necessary by the City of Santa Clarita.
- GC8. The owner, at the time of issuance of permits or other grants of approval, agrees to develop the property in accordance with City codes and other appropriate ordinances such as the Building Code, Plumbing Code, Grading Code, Highway Permit Ordinance, Mechanical Code, Unified Development Code, Sanitary Sewer and Industrial Waste Ordinance, Electrical Ordinance and Fire Code.

- GC9. Details shown on the site plan are not necessarily approved. Any details which are inconsistent with the requirements of state or local ordinances, general conditions of approval, or City policies and not modified by this permit must be specifically approved in writing.
- GC10. It is hereby declared and made a condition of this permit that if any condition hereof is violated, or if any law, statute, or ordinance is violated, the City may commence proceedings to revoke this approval.
- GC11. The applicant must sign and notarize the attached affidavit to confirm acceptance of the conditions of this grant. The notarized affidavit must then be returned to the Planning Division before occupancy.

PLANNING DIVISION

- PL1. The applicant shall be permitted to install appropriate signage for the various tenant spaces as shown in the approved sign program. This includes:
- A. One sign per tenant space on both the parking lot elevation and the street-side elevation. The number of signs allowed will depend on the number of tenant spaces.
 - B. Two (2), two-sided monument signs measuring 6'-0" high and 12'-0" wide, for a total area of 72.0 square feet. The subject signs shall be set back a minimum of one foot from the right-of-way. One sign shall be permitted at the shopping center entrance on Golden Valley Road, and the other sign shall be permitted at the entrance on Sierra Highway as shown in the approved sign program.
- PL2. The proposed signs shall be developed in conformance with the approved plans on file in the Planning Division. Any changes shall be subject to further review by the Director of Community Development.
- PL3. This approval does not supersede the requirements of any other affected agency or of any requirements or prohibitions in the Unified Development Code not addressed above.
- PL4. The signs shall not be located in such a manner as to impede traffic or sight visibility.
- PL5. No exposed or open neon is allowed.

If you have any questions regarding this application, I can be reached at (661) 255-4330.

Sincerely,



Ben Jarvis
Associate Planner

FEB 09 2016

THE SHOPS AT GOLDEN VALLEY



- SUBJECT to the CONDITIONS of APPROVAL FOR MC 15-183.
- ORIGINALLY APPROVED ON 11/6/2015.
- UPDATED ON 2/9/16



SIGN PROGRAM
UPDATED NOVEMBER 2015
REVISION FEBRUARY 9 2016

DEVELOPER
 Robert Cristiano c/o
 Intertex Companies
 28338 Constellation Road #900
 Valencia, CA 91355

SIGN
 CONSULTANT
 Signs and Designs
 620 East Rancho Vista Blvd
 Palmdale, CA 93550
 661-947-4473
 hello@signsanddesigns.tv

ARCHITECT
 Ware Malcolm
 10635 Santa Monica Blvd #150
 Los Angeles, CA 90025
 P 310.481.0400

TABLE OF CONTENTS

Objective	Page 1	Prohibited Signs	9
Tenant Requirements	2	Signs Allowed W/ Landlord Approval	10
Developer Standards	2	Lighting Specification	11
Approval Process	3	Lighting Specifications Cont	12
Sign Specifications	4	Main Monument Sign	13
Sign Specifications Cont	5	M1/M2 Monument Sign	14
Sign Specifications Cont	6	Monument Sign Specifications	15
Construction Requirements	7	Front Entry Door Graphics	16
Installation Requirements	8	Site Plan	17

OBJECTIVE

This Sign Program ("Program") has been established for The Shops at Golden Valley, Golden Valley Road Retail Center Santa Clarita, CA. This Program sets the standards and maintenance for high quality, Class "A" signage to be erected within the Center. This Program will assure consistency in design, construction and maintenance for the benefit of the community, the Center and all Center Owners and tenants.

Tenants within the Center may seek and obtain signage on the monument sign within the Center under separate approval from an agreement with the Developer and/or Owner, respectively, and subject to availability.

TENANT REQUIREMENTS

- Tenant shall submit to the Landlord, or cause to be submitted for written approval, one copy of detailed drawings indicating the location, size, layout, design and color of the proposed signs, including all lettering and/or graphics.
- Tenant shall submit a sign drawing approved by the Landlord to the appropriate City authority for approval prior to the start of any sign construction or fabrication.
- Tenant shall pay for building signs and Monument/Pylon Sign Faces (if available to tenant), their installation (including final connection, transformers and all other labor and materials) and maintenance.
- Tenant shall obtain all necessary permits.
- Tenant shall be responsible for fulfillment of all requirements in this program.
- NOTE! No sign shall be constructed until all required permits are obtained from the City of Santa Clarita.
- Tenants are responsible for the removal of all signs (includes filling and patching of holes) no later than 14 days after the expiration or earlier termination of their lease.

DEVELOPER STANDARDS

- Building base design and construction information will be provided will be provided to tenant on request.
- Landlord to provide one connection point for primary electrical service at the interior wall or canopy for building signs.
- Monument Signs shall be designed, constructed and maintained by Landlord in accordance with the monument sign specifications.
- Monument and Pylon signage placement and availability shall be at the sole discretion of Landlord.

APPROVAL PROCESS

- Tenants shall provide by email, PDF fully dimensioned shop drawings of Tenant's proposed signage, including:
 - Store Name
 - Store Logo with colors identified
 - Entire building facade elevation showing proposed sign
- Storefront/partial building elevation showing location, size, color, construction and installation details. Include typical "section-through" lettering and/or sign panel showing the dimensioned projection of letters or panel face and Illumination method.
- Color and material samples with photograph, if available, of similar installation.
- Within ten (10) days of receipt of Tenant's sign submission, Landlord will approve or disapprove Tenant's proposed sign(s). Disapproved will include reasons for disapproval. Approval will not be unreasonably withheld.
- Any re-submittal to Landlord of a proposed sign submission must include revisions in response to Landlord's disapproved comments.
- Upon written Landlord approval of the proposed signage, Tenant may submit its application to the City of Santa Clarita in accordance with City guidelines.
- It is the Tenant's responsibility to ascertain and comply with City of Santa Clarita's ordinances and/or other governing regulations concerning the city approval process and City issued sign permits.
- Tenant shall provide one set of City approved drawings and a copy of the permit to Landlord prior to commencing Installation.

SIGN SPECIFICATIONS

SUBJECT TO CITY APPROVAL

LIGHTING

Creative illumination is encouraged. Acceptable lighting styles include Light Emitting Diodes (LEDs).

COLORS

Colors should provide sufficient contrast against exterior building colors and overall center colors and trim.

Colors should be compatible with, and complement building colors.

Nationally and regionally recognized logo colors may be used.

STYLES

Signage should be architecturally compatible with overall shopping center design and should promote the upscale, class "A" overall Center environment. The following styles may be incorporated:

Creative use of front, halo and backlit illumination.

Channel letters, 3-inch deep minimum.

Mixed media/dimensional signs using images, icons, logos, etc.

Dimensional geometric shapes.

Complex shaped sign cabinets (if part of national logo, may be used alone if dimensional elements such as push-through letters are incorporated).

Script fonts, only if part of established trademark and used in other locations.

Sign may identify business name and generic word description of service (excludes product identity and specific service descriptions).

SIGN SPECIFICATIONS CONTINUED

DIMENSIONS AND PLACEMENT

Building signs to be centered on storefront.

No Building sign shall exceed 75% of storefront width.

20 SF minimum, 100 SF maximum single sign size calculated based on 1 1/2 SF of sign area per 1 LF of leasehold building frontage.

One (1) Building sign per tenant, except
Building elevations facing multiple exposures (e.g., parking lot or street) may incorporate one (1) additional sign per elevation.

All proposed signs (storefront and secondary street frontage, mall or parking) to be a minimum of 24" Overall and maximum of 42" in height with a minimum letter height to be 8" tall.

Stacked copy is allowable provided that the maximum height does not exceed the limits above.

Size area measured by drawing (i.e., rectangle, circle) around each separate element of the sign, area of letters measured separately from area of icon and/or logo.

All signs subject to final approval of Landlord and City of Santa Clarita.

SIGN SPECIFICATIONS CONTINUED

MAXIMUM 75%
OF ADJACENT SURFACE LENGTH

3'-6" MAX.
LETTER HEIGHT

SHOP TENANT



CONSTRUCTION REQUIREMENTS

Fastening hardware and clips are to be concealed. All letters will be attached according to City specifications.

No labels will be permitted on the exposed surface of signs, except those required by local ordinance and shall be placed in an inconspicuous location.

All penetrations of the building structure required for sign installation shall be sealed in a watertight condition and shall be patched to match adjacent finish. No wiring or transformers shall be visible.

All signage will be provided a standard lead wire of electrical on the fascia area of their storefront. Timers, Photo Cells, or switches that operate the function of the sign will be the responsibility of the tenant.

Signs must be fabricated of durable appropriate weather resistant materials complementary to the base building materials.

Dissimilar metals used in sign fabrication shall be separated with non-conductive gaskets to avoid electrolysis. Stainless steel fasteners shall be used to attach dissimilar metals

Threaded rods or anchor bolts shall be used to mount sign letters which are held off the background panel. Angle clips attached to letter sides will NOT be permitted.

Colors, materials, finishes shall exactly match those submitted to and approved by the Landlord.

Visible welds and seams shall be ground smooth and filled with auto body compound before painting.

Finished metal surfaces shall be free from canning and warping. All sign finishes shall be free of dust, orange peel, drips and runs and shall have a uniform surface conforming to the highest industry standards.

INSTALLATION REQUIREMENTS

- Sign Contractors must be California licensed contractors with a current city business license.
- All work shall be performed in accordance with City of Santa Clarita's minimum standards.
- If requested by Landlord, Sign Contractor must provide original certificate of insurance naming Landlord as additional insured for liability coverage in an amount to be determined by Landlord.
- Tenant to deliver to Landlord, prior to commencing sign installation, copy of stamped City of Santa Clarita's sign permit.
- Full set of City-approved sign construction plans to be maintained on site at all times during sign construction and installation.
- Tenant is responsible for any and all damage caused by sign contractor, sign construction and installation.
- Tenant is responsible for repairing any damage to structure or any part of Center resulting from work associated with sign construction or installation.
- Electrical service to signs shall be the responsibility of the Tenant.

PROHIBITED SIGNS

- No audible, flashing, oscillating, moving or animated signs.
- No projections above or below the sign panel. Signs must be within dimensioned limits as indicated herein.
Window signs or signs blocking doors or fire escapes, unless approved by the Landlord.
- Paper, cardboard, or Styrofoam signs, stickers, or decals hung around or behind storefronts (Except those required by governmental agencies).
- Rooftop signs or signs projecting above roof lines or parapets.
- A sign that consists of only an unadorned rectangular cabinet signs with translucent or opaque faces.
- Pre-manufactured signs, such as franchise signs that have not been modified to conform with this Program.
- Simulated materials such as wood grained plastic laminates or wall coverings.
- Signs on mansard roofs or equipment screens.
- Advertising or promotional signs on parked vehicles.
- Painted signs
- Portable and A-frame signs
- Wind-activated and balloon signs
- Outdoor advertising structures (billboards)
- Exposed junction boxes, exposed wires, plug-in wires on window signs, transformers, lamps, tubing, conduits, raceways, exposed neon or neon crossovers of any type.

SIGNS ALLOWED

WITH WRITTEN LANDLORD APPROVAL

Decorative fasteners essential to sign design concept

Sign company decal in full view, during sign installation only (limited to one)

Raceways are discouraged, but may be permitted, so long as they are painted to match surface to which they are affixed.

Mixed media signage

Temporary Wall or Building signs, pennants, banners, inflatable displays or sandwich boards, unless used in connection with pre-opening, pre grand opening or grand opening events. Permits shall be obtained from the City of Santa Clarita. Subject to City ordinances and all requirements as to use, duration and placement.

Any other sign type or style not described in or expressly prohibited by this Program

LIGHTING SPECIFICATIONS

HALO ILLUMINATION

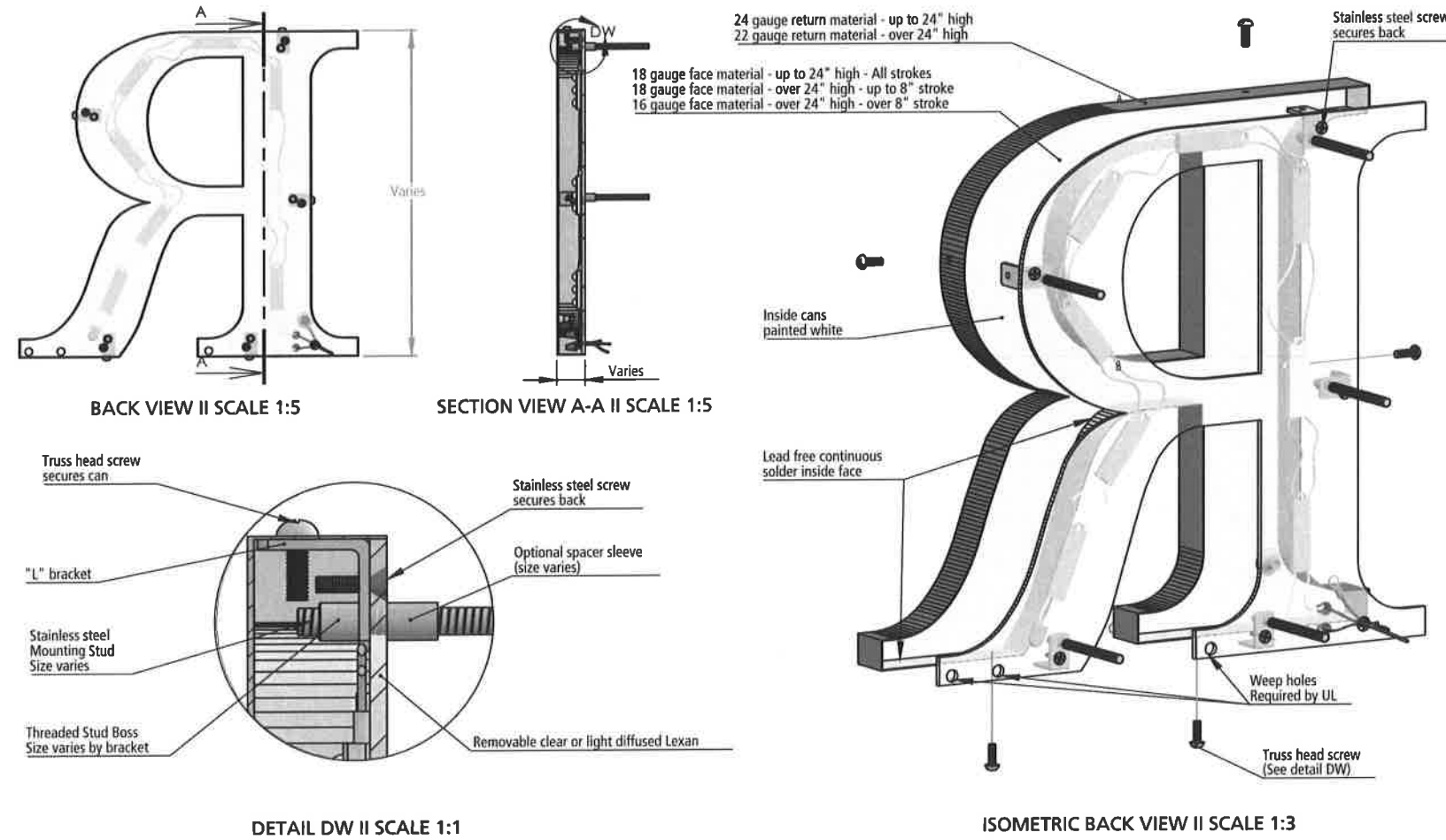

BACK OPTIONS

- Clear Lexan: 6-24" high - 0.118" thick, over 24" - 0.236" thick
- Light diffused Lexan: 0.177" thick

MATERIAL OPTIONS

- Standard - 304 prefinished stainless steel
- Optional - 316 prefinished stainless steel (more corrosion resistant)
- 304 prefinished stainless with titanium coating

LIGHTING SPECIFICATIONS

FRONT ILLUMINATION

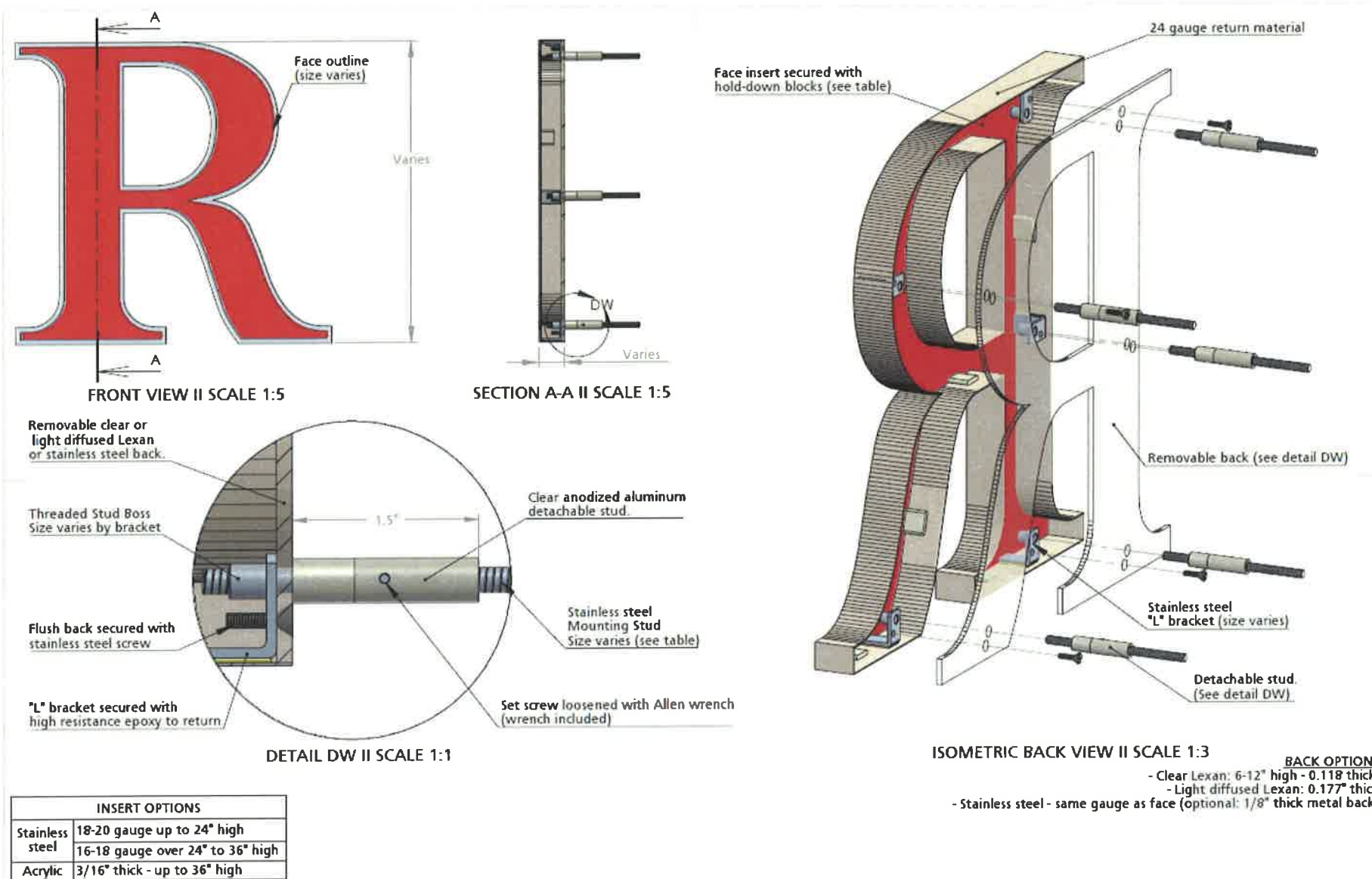

MONUMENT SIGN



MONUMENT SIGN SPECIFICATIONS

One Double Sided Monument Sign shall be permitted on each entrance to the property per Master Site Development Plan not to exceed two monuments. Signage to be Aluminum Construction and to have same architectural style as building with matching colors. Not to exceed 6' height maximum with the overall sign area square footage not to exceed 72 sf. Monuments shall be placed atleast 1' 0" from the property line.

All monument lettering including font, color, text, and placement must be approved by Landlord.

Monument sign placement and availability at Landlord's sole discretion.

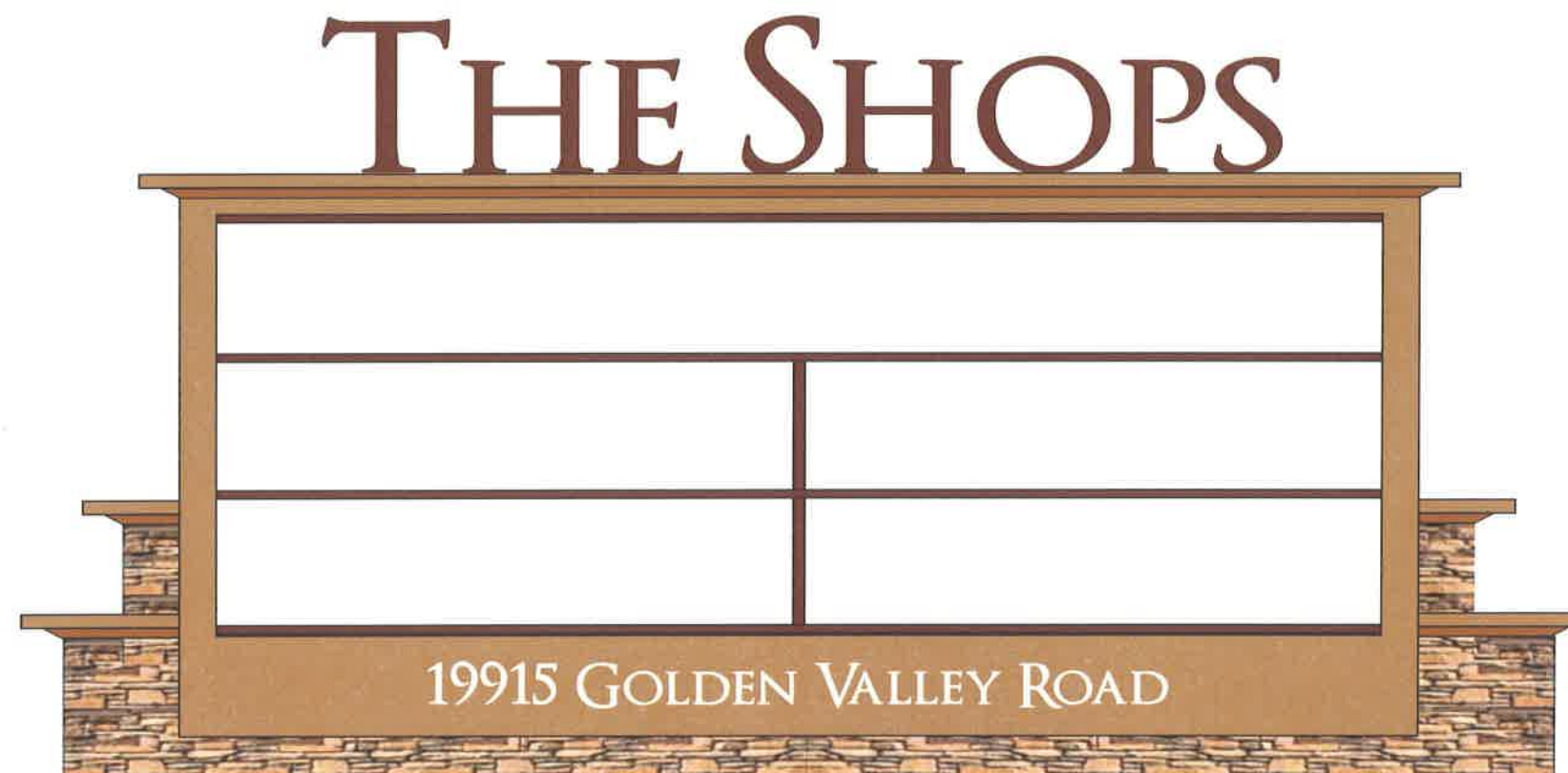

FRONT ENTRY DOOR GRAPHICS

- Each public entry door shall be permitted decal application lettering on one window, indicating hours of business, emergency telephone numbers, et cetera. This shall not exceed 15% of the overall size of the window area, per the City of Santa Clarita.

REAR / NON-PUBLIC ENTRY DOORS

- Each non-customer door for receiving merchandise may display the tenant's name and address in 2" high block letters.

SPECIFICATIONS:

- 6" HIGH WHITE VINYL NUMBERS/LETTERS ON ENTRY GLASS ABOVE DOOR.
- "STORE HOURS" TO BE WHITE VINYL ON WINDOW NEXT TO DOOR.
- ALL VINYL TO BE APPLIED SECOND SURFACE.
- 2.5 SQ. FT. MAXIMUM SIGN AREA.



TYPICAL FRONT ENTRY ELEVATION

SPECIFICATIONS:

- 4" AND 2" HIGH VINYL NUMBERS/LETTERS ON REAR ENTRY DOOR.
- COLOR TO BE IN CONTRASTING COLOR TO DOOR.
- 2.5 SQ. FT. MAXIMUM SIGN AREA.

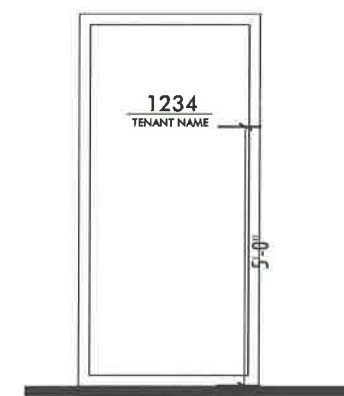

TYPICAL REAR ENTRY ELEVATION

SITE PLAN

MONUMENTS SHALL NOT ENCROACH
INTO PARKING SPACES

