

Canyon Country Plaza

Sign Program

19000 Soledad
Canyon Road

APPROVED

By Andrew Collier at 9:21 am, Jul 28, 2022

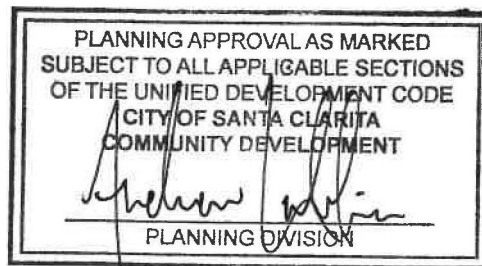

MC22-138
Approval for Master Sign
Program revision.

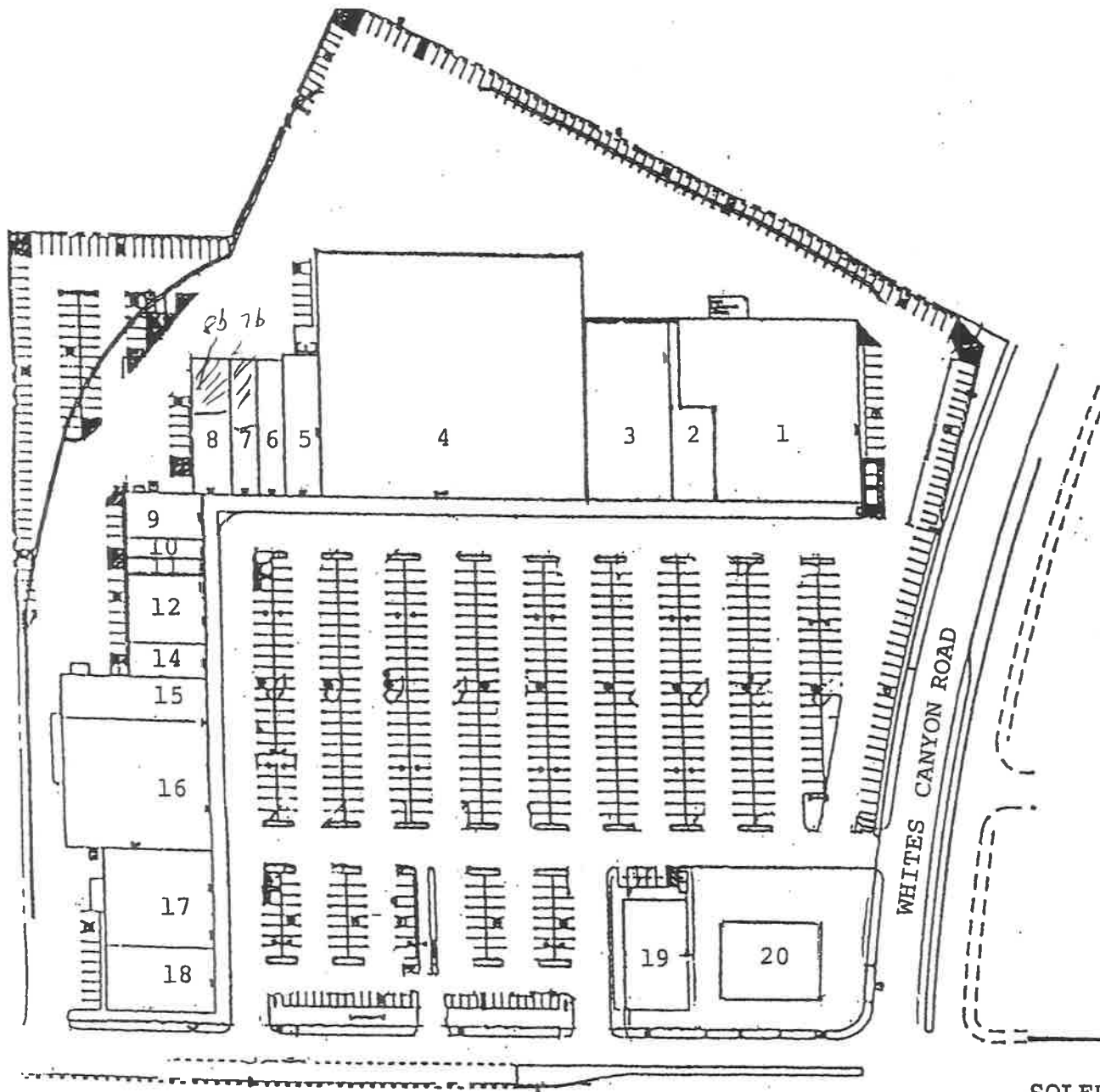

| # | TENANT | SQ. FT. | DIMENSION +/- |
|-----|------------------------|-------------|---------------|
| 1. | Staples | 23,200 | 130 x 160 lrg |
| 2. | <i>Sen World</i> | 3,600 | 40 x 90 lrg. |
| 3. | Mainly Seconds | 12,000 | 75 x 160 |
| 4. | Food 4 Less | 54,930 | 250 x 220 lrg |
| 5. | Payless Shoe Source | 4,375 | 35 x 125 |
| 6. | Computer | 3,000 | 25 x 120 |
| 7. | Sally Beauty | 1,500 | 25 x 60 |
| 8. | Canyon Eye Ctr. | <i>3000</i> | 35 x 120 |
| 9. | Surf Trader | 2,800 | 40 x 70 |
| 10. | Dry Cleaners | 1,120 | 16 x 70 |
| 11. | G.N.C. | 980 | 14 x 17 |
| 12. | <i>Robb's MacPizza</i> | 4,200 | 60 x 70 |
| 14. | Basha Chicken | 2,100 | 30 x 70 |
| 15. | Pet Adventure | 5,911 | 41.5 x 134 lr |
| 16. | Beverly Crafts | 14,200 | 106 x 134 |
| 17. | El Chaparral | 8,200 | 82 x 100 |
| 18. | Bank of America | 6,300 | 63 x 100 |
| 19. | Blockbuster | 6,500 | 65 x 100 |
| 20. | Chevron | N/A | N/A |

8b. Storage - 1200
7b. OFF. - 1500

SOLEDAD CANYON ROAD

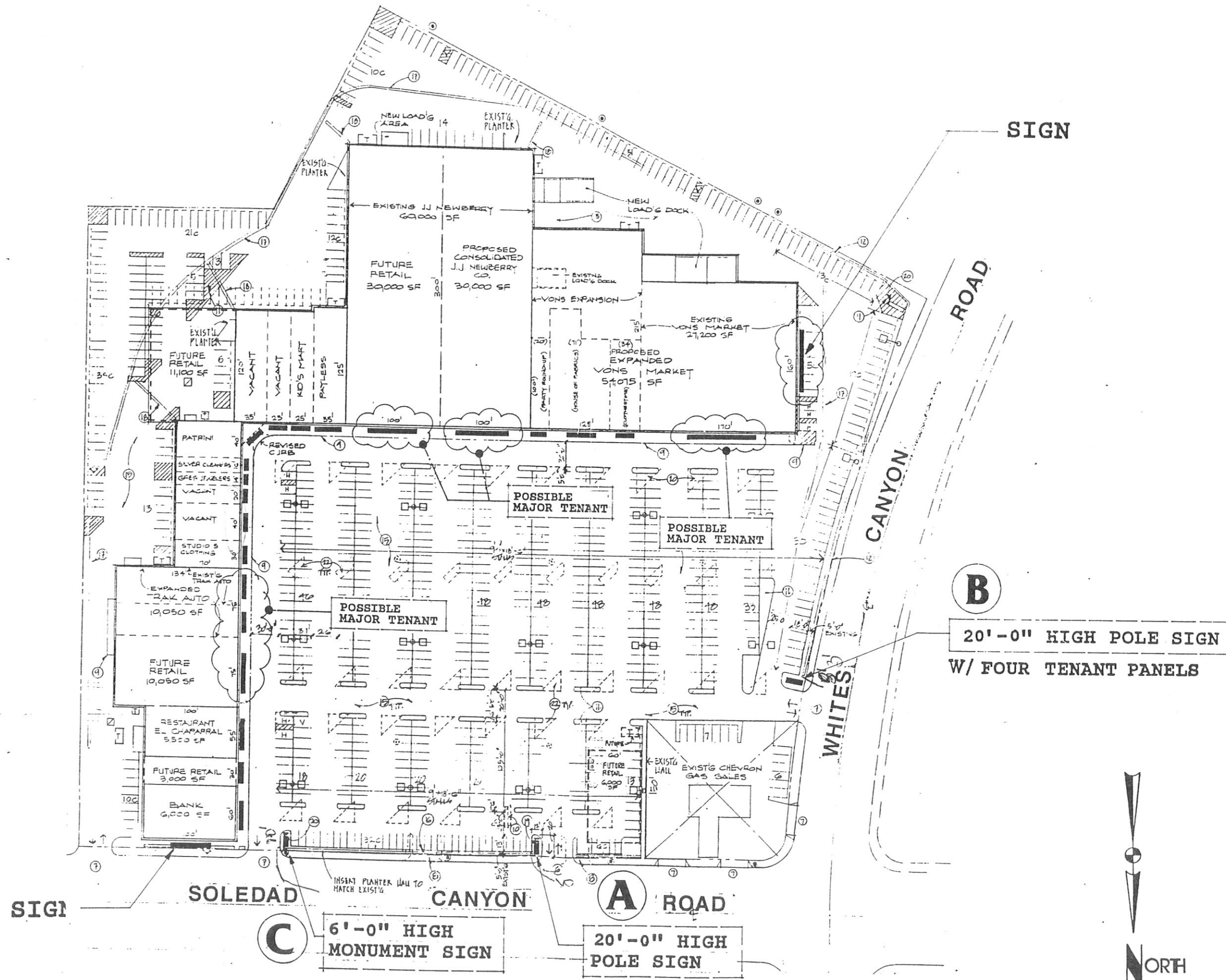

SAN PEDRO ELECTRIC SIGN COMPANY
 701 Lakme Avenue
 Wilmington, California 90744
 310/549-4661
 FAX 310/49-2482

| NO | DATE | BY | REVISIONS | | | | |
|----|---------|----|-----------|---|---|---|---|
| | | | 1 | 2 | 3 | 4 | 5 |
| 1 | 7-19-93 | JJ | | | | | |
| 2 | 7-26-93 | JJ | | | | | |
| 3 | 8-16-93 | JJ | | | | | |
| 4 | 9-16-93 | JJ | | | | | |
| 5 | | | | | | | |

JOB NAME **CANYON COUNTRY PLAZA**
 ADDRESS **19000 SOLEDAD CANYON ROAD**
 DRAWN BY **JJ**
 SALESMAN **M. FRANK**
 CUSTOMER APPROVAL

SCALE **NTS**
 SHEET NO **5 OF 5**
 DATE **06-23-93**
 DRAWING NUMBER **93-6-2808E R4**

THIS IS AN ORIGINAL UNPUBLISHED DRAWING CHECKED BY SAN PEDRO SIGN COMPANY. IT IS NOT TO BE SHOWN TO ANYONE OUTSIDE YOUR ORGANIZATION, NOR IS IT TO BE USED, REPRODUCED, COPIED OR EXHIBITED IN ANY MANNER.

24" MAXIMUM LETTER AND LOGO HEIGHT.
SIGN LENGTH NOT TO EXCEED 70% OF
LEASEHOLD WIDTH.

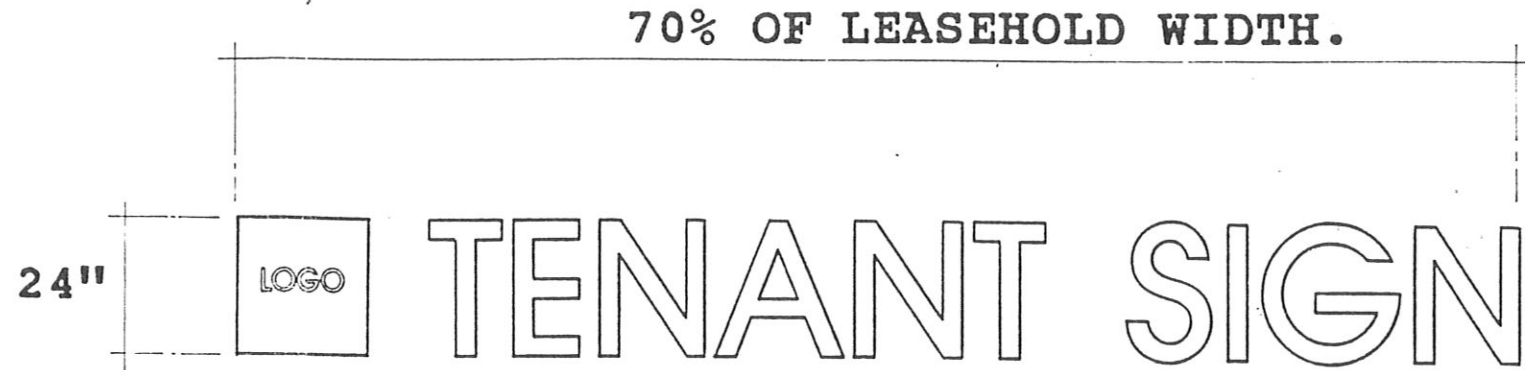
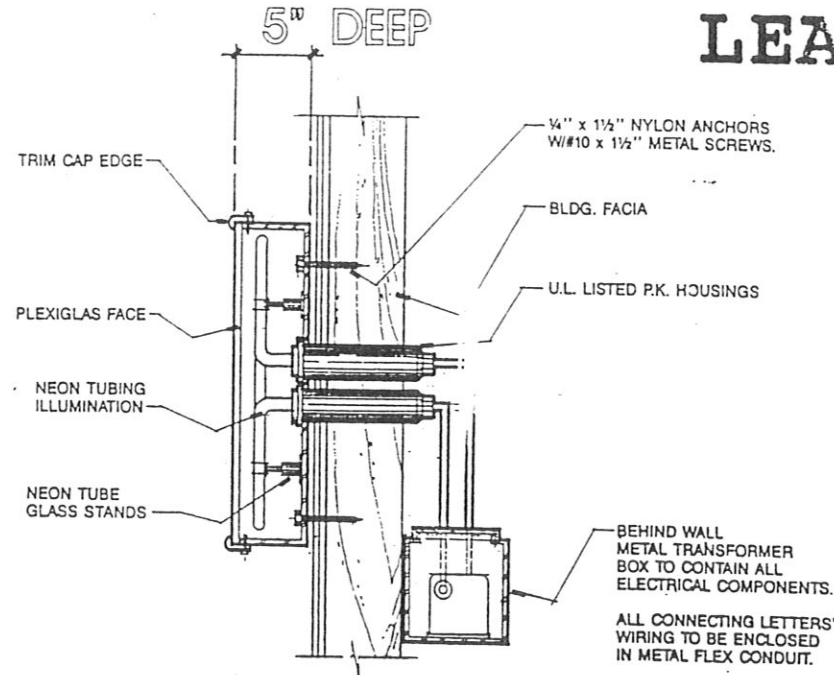

| LEASEHOLD | | LEASEHOLD | | LEASEHOLD WIDTH | | |
|-----------|----------|-----------|----|-----------------|---|----|
| EQ | 70% SIGN | EQ | EQ | 70% SIGN | EQ | EQ |
| | | | | | SIGN LENGTH NOT TO EXCEED 70% OF LEASEHOLD WIDTH. | |

Approved AS MAINT
M. Frank
DIRECTOR OF COMMUNITY DEVELOPMENT
SANTA CLARITA
-subject to conditions
of DR-93-031
MC-93-146

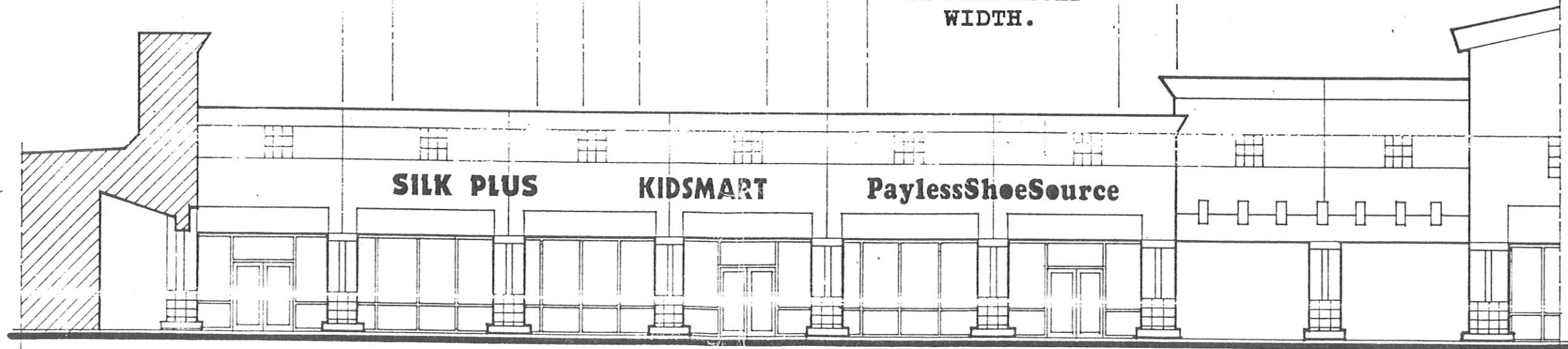

IN-LINE TENANT

JOB NAME CANYON COUNTRY PLAZA

ADDRESS 19000 SOLEDAD CANYON ROAD SANTA CLARITA, CA

DRAWN BY JJ

SALESMAN M. FRANK

CUSTOMER APPROVAL

SCALE 1/8"

SHEET NO. 1 OF 5

DATE 06-23-93

DRAWING NUMBER 93-6-2808A

REVISIONS

| NO. | DATE | BY |
|-----|------|----|
| 1 | | |
| 2 | | |
| 3 | | |
| 4 | | |
| 5 | | |

SAN PEDRO ELECTRIC SIGN COMPANY
701 Lakme Avenue
Wilmington, California 90744
310/549-4661
FAX 310/549-2482

SPESCO

THIS IS AN ORIGINAL UNPUBLISHED DRAWING CREATED BY SAN PEDRO SIGN COMPANY. IT IS SUBMITTED FOR YOUR PERSONAL USE IN CONNECTION WITH A PROJECT BEING PLANNED FOR YOU BY SAN PEDRO SIGN COMPANY. IT IS NOT TO BE SHOWN TO ANYONE OUTSIDE YOUR ORGANIZATION, NOR IS IT TO BE USED, REPRODUCED, COPIED OR EXHIBITED IN ANY MANNER.

5'-0" MAXIMUM LETTER AND LOGO HEIGHT.
 SIGN LENGTH NOT TO EXCEED 70% OF
 LEASEHOLD WIDTH.
 MAJOR TENANTS SIGNAGE SUBJECT TO
 LANDLORD APPROVAL.

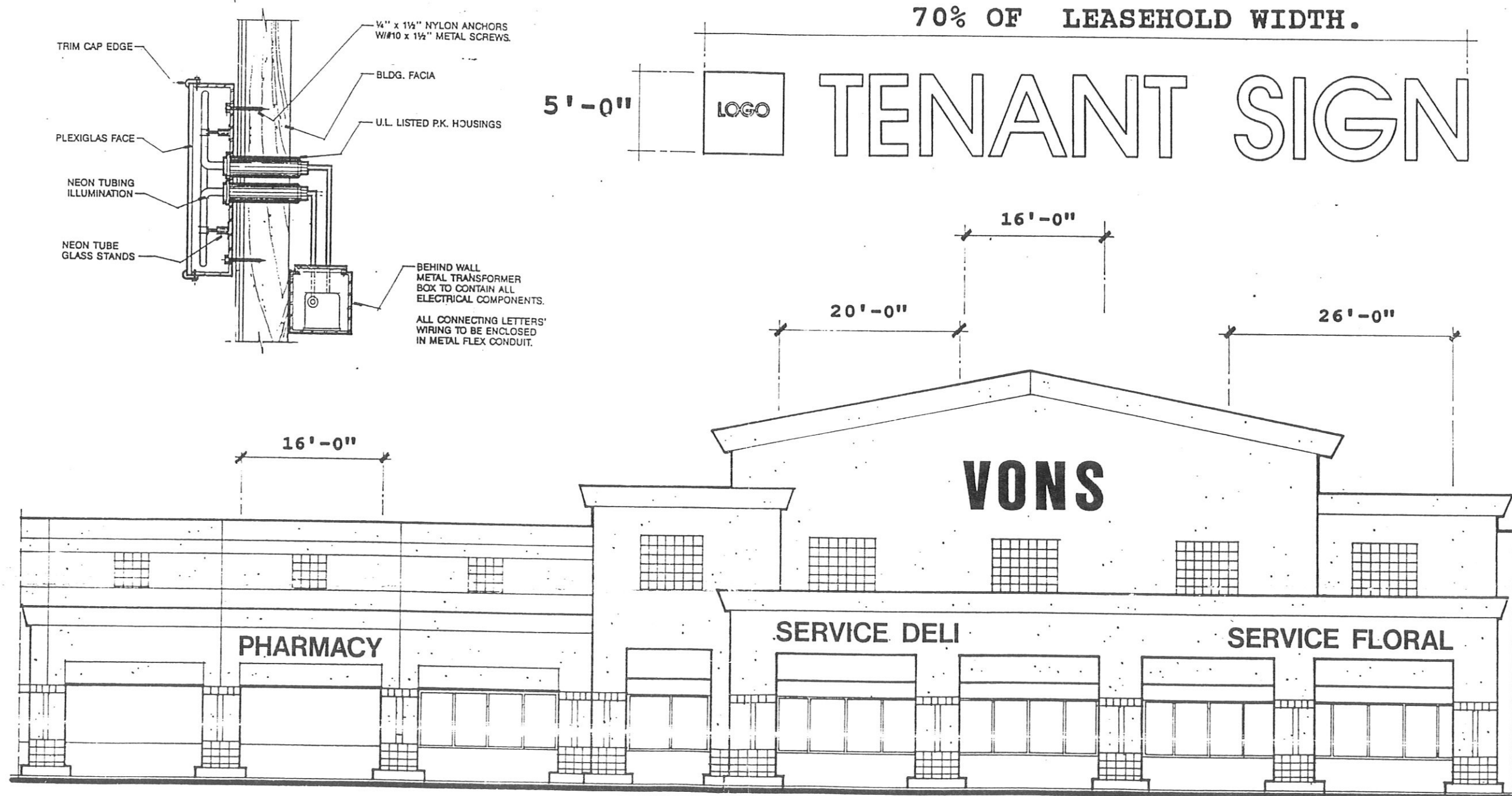

Major Tenant Spaces 1 & 4

JOB NAME: CANYON COUNTRY PLAZA
 ADDRESS: 19000 SOLEDAD CANYON ROAD SANTA CLARITA, CA
 SCALE: 1/8" SHEET NO. 2 OF 5
 DRAWN BY: JJ DATE: 06-23-93 DRAWING NUMBER: 93-6-2808B
 SALESMAN: M. FRANK
 CUSTOMER APPROVAL:

| NO. | DATE | REVISIONS |
|-----|------|-----------|
| 1 | | |
| 2 | | |
| 3 | | |
| 4 | | |
| 5 | | |

SAN PEDRO ELECTRIC SIGN COMPANY
 701 Lakme Avenue
 Wilmington, California 90744
 310/549-4761
 FAX 310/49-2482

THIS IS AN ORIGINAL UNPUBLISHED DRAWING CREATED BY SAN PEDRO SIGN COMPANY. IT IS NOT TO BE SHOWN TO ANYONE OUTSIDE YOUR ORGANIZATION. NOT TO BE REPRODUCED, COPIED OR EXHIBITED IN ANY WAY.

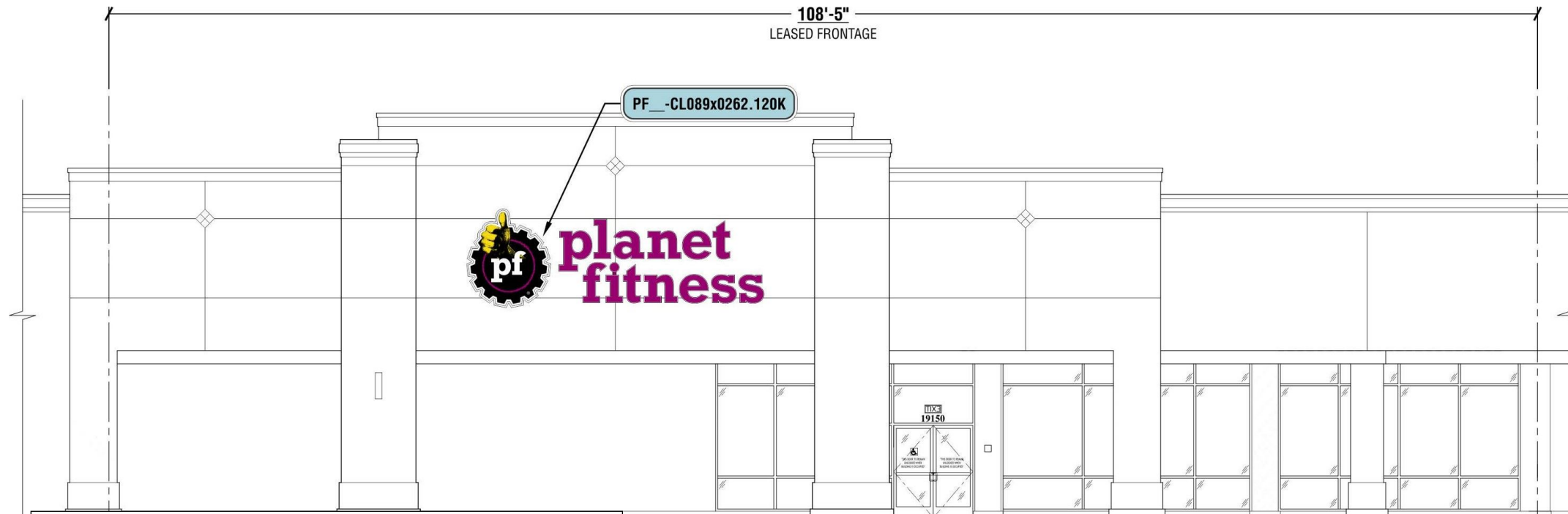

108'-5"
LEASED FRONTAGE

PF_-CL089x0262.120K



7'5" MAXIMUM LETTER AND LOGO HEIGHT.
SIGN LENGTH NOT TO EXCEED 70% OF LEASEHOLD WIDTH.
MAJOR TENANT SIGNAGE SUBJECT TO LANDLORD APPROVAL.

Major Tenant Space 16

70% OF LEASEHOLD WIDTH.

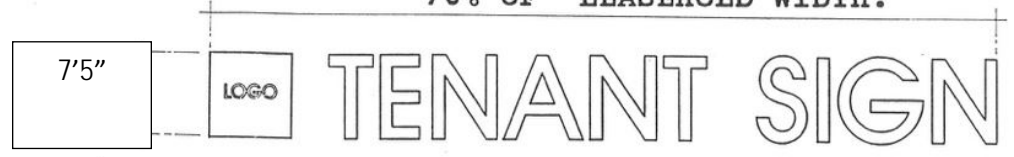

7'5"

LOGO

TENANT SIGN

IDENTITY.

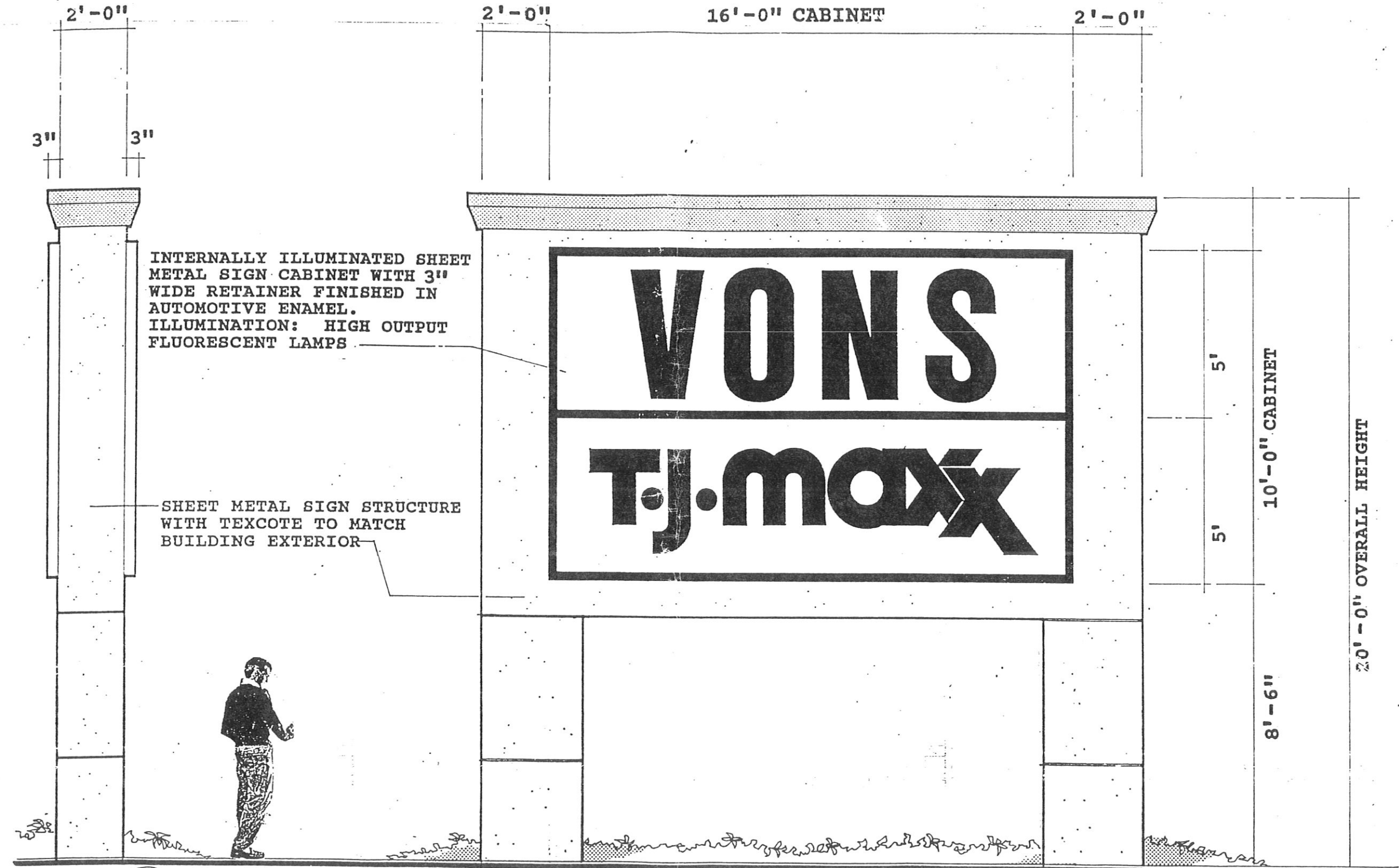

INTERNALLY ILLUMINATED SHEET METAL SIGN CABINET WITH 3" WIDE RETAINER FINISHED IN AUTOMOTIVE ENAMEL. ILLUMINATION: HIGH OUTPUT FLUORESCENT LAMPS

SHEET METAL SIGN STRUCTURE WITH TEXCOTE TO MATCH BUILDING EXTERIOR

NOTE: 1. VANSI BANNER SUBJECT TO CHANGE. LOWER PANEL MAY BECOME TWO PANELS.

A INTERNALLY ILLUMINATED DOUBLE-FACED MULTI-TENANT POLE SIGN.
160.0 SQ. FT.

| | | |
|---------------------------------|---------|---|
| REVISIONS NO. DATE BY | | JOB NAME CANYON COUNTRY PLAZA |
| 1 | | ADDRESS 19000 SOLEDAD CANYON ROAD |
| 2 | | CITY SANTA CLARITA, CA |
| 3 | | DRAWN BY JJ |
| 4 | | SALESMAN M. FRANK |
| 5 | 9-15-93 | CUSTOMER APPROVAL |
| | | SCALE 1/2" |
| | | SHEET NO. 3 OF 5 |
| | | DATE 06-23-93 |
| | | DRAWING NUMBER 93-6-2808C.R. |

SAN PEDRO ELECTRIC SIGN COMPANY
 701 Lakme Avenue
 Wilmington, California 90744
 310/549-4661
 FAX 310/549-2482

THIS IS AN ORIGINAL UNPUBLISHED DRAWING. IT IS NOT TO BE SHOWN TO ANYONE OUTSIDE YOUR ORGANIZATION. NOR IS IT TO BE USED, REPRODUCED, COPIED OR EXHIBITED IN ANY WAY.

COPY. COLORS PER CORPORATE IDENTITY.

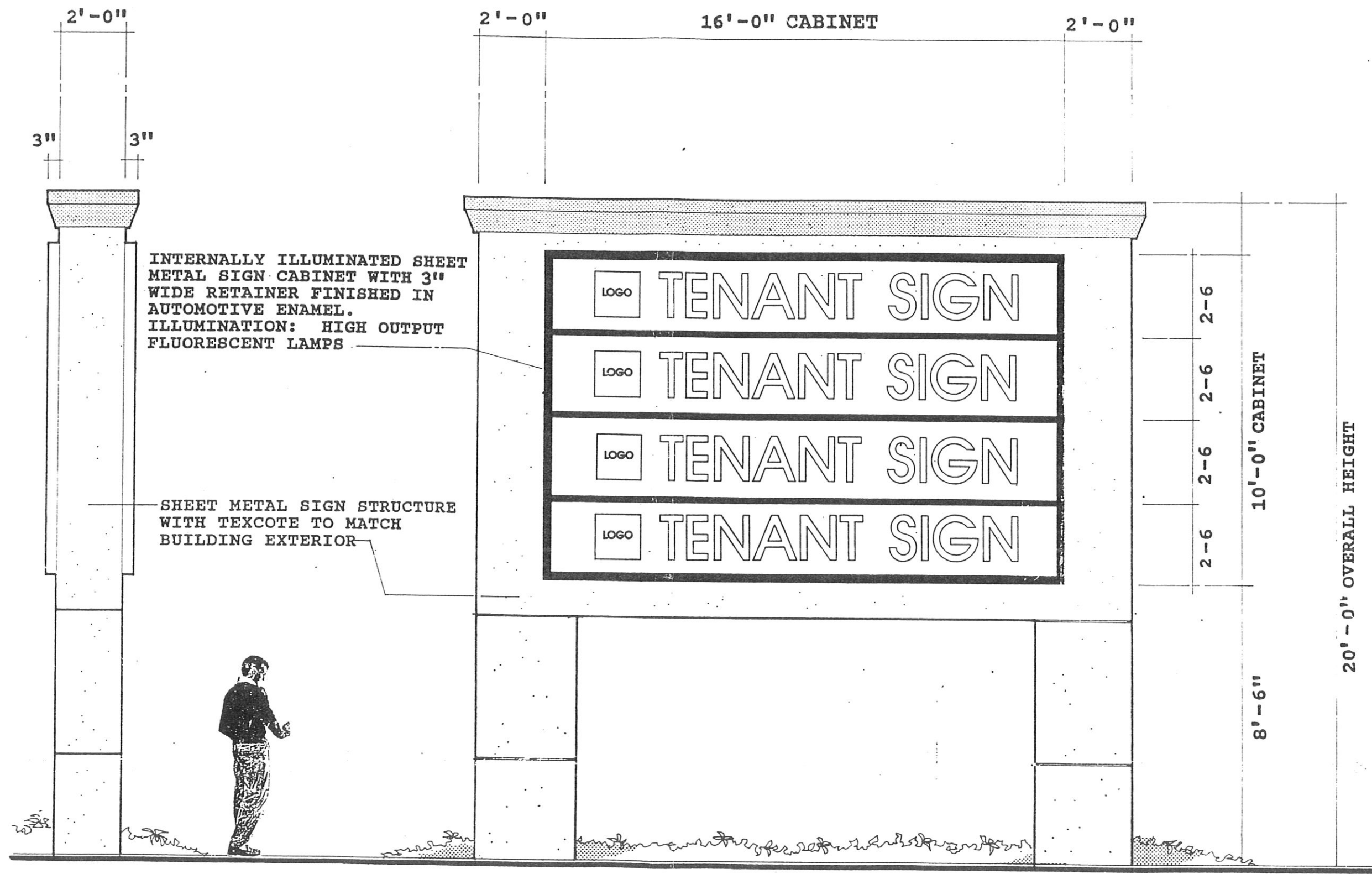

B INTERNALLY ILLUMINATED DOUBLE-FACED MULTI-TENANT POLE SIGN.
160.0 SQ. FT.

SAN PEDRO ELECTRIC SIGN COMPANY
 701 Lakma Avenue
 Wilmington, California 90744
 310/549-4661
 FAX 310/49-2482

| REVISIONS | | NO | DATE | BY |
|-----------|--|----|---------|----|
| 1 | | | | |
| 2 | | | | |
| 3 | | | | |
| 4 | | | | |
| 5 | | | 1-15-93 | |

JOB NAME: CANYON COUNTRY PLAZA
 ADDRESS: 19000 SOLEDAD CANYON ROAD
 DRAWN BY: JJ
 SALESMAN: M. FRANK
 CUSTOMER APPROVAL: _____

SANTA CLARITA, CA
 SCALE: 1/2"
 DATE: 06-23-93
 SHEET NO: 3 OF 5
 FIG. NO: 93-6-2808C R5

THIS IS AN ORIGINAL UNPUBLISHED DRAWING CREATED BY SAN PEDRO SIGN COMPANY. IT IS NOT TO BE SHOWN TO ANYONE OUTSIDE YOUR ORGANIZATION NOR IS IT TO BE USED, REPRODUCED, COPIED OR EMPLOYED IN ANY WAY.

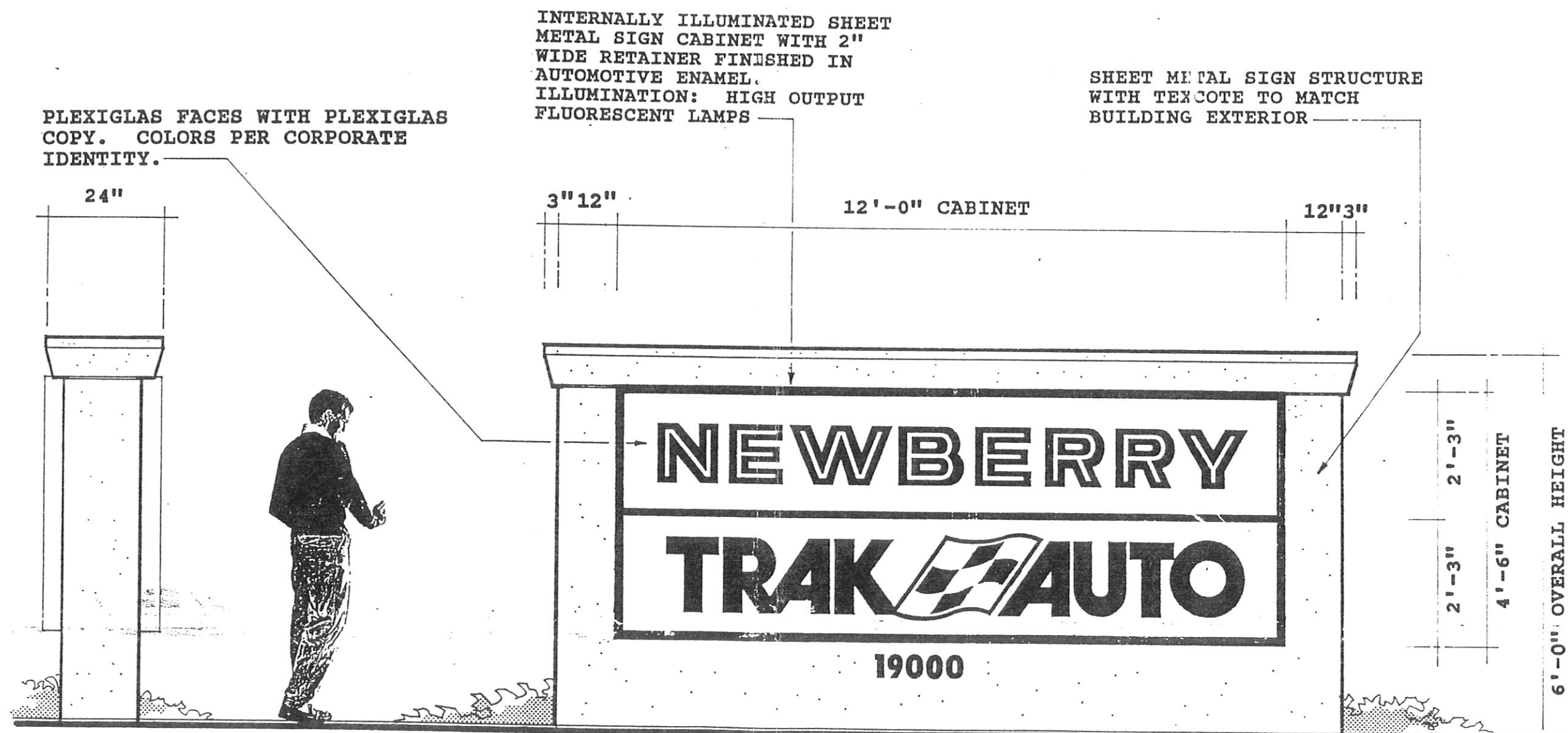

PLEXIGLAS FACES WITH PLEXIGLAS COPY. COLORS PER CORPORATE IDENTITY.

INTERNALLY ILLUMINATED SHEET METAL SIGN CABINET WITH 2" WIDE RETAINER FINISHED IN AUTOMOTIVE ENAMEL. ILLUMINATION: HIGH OUTPUT FLUORESCENT LAMPS

SHEET METAL SIGN STRUCTURE WITH TEXCOTE TO MATCH BUILDING EXTERIOR

24"

3" 12"

12'-0" CABINET

12" 3"

2'-3" 2'-3"

4'-6" CABINET

6'-0" OVERALL HEIGHT

C INTERNALLY ILLUMINATED DOUBLE-FACED MULTI-TENANT MONUMENT SIGN.
54 SQ.FT.

| | | | |
|--|---------|---|--|
| SAN PEDRO ELECTRIC SIGN COMPANY 701 Lakme Avenue Wilmington, California 90744 310/549-4161 FAX 310/519-2482 | | JOB NAME CANYON COUNTRY PLAZA | |
| ADDRESS 19000 SOLEDAD CANYON ROAD | | CITY SANTA CLARITA, CA | |
| DRAWN BY JJ | | SCALE 3/4" | |
| SALESMAN M. FRANK | | DATE 06-23-93 | |
| CUSTOMER APPROVAL | | SHEET NO 4 OF 5 | |
| REVISIONS | | DRAWING NUMBER 93-6-2808DR2 | |
| NO | DATE | BY | |
| 1 | 8-16-93 | JJ | |
| 2 | 9-16-93 | JJ | |
| 3 | | | |
| 4 | | | |
| 5 | | | |



THIS IS AN ORIGINAL UNPUBLISHED DRAWING CREATED BY SAN PEDRO SIGN COMPANY. IT IS NOT TO BE SHOWN TO ANYONE OUTSIDE YOUR ORGANIZATION. NO IT IS TO BE USED. REPRODUCED, COPIED OR ILLUSTRATED IN ANY MANNER.