

TYPICAL ROOFED PATIO COVER

For information on obtaining a permit for a patio cover and completing these drawings see Page 4.

TO COMPLETE THIS PLOT PLAN . . .

1. Show the location of the proposed patio cover on the plot plan below showing its size, area and distance to property lines. Also show the location and spacing of the supporting posts.
2. Show any other structures in the same yard as the proposed patio cover, such as pools, retaining walls, accessory buildings and oak trees. Dimension these items from the patio cover.
3. Show any hillsides on your property that exceed a slope of 3 horizontal to 1 vertical (3:1). Show the distance from the top or bottom of these slopes to the proposed patio cover. Indicate on the plan the slope of the grade and the vertical height of the slope from top to bottom.
4. Setbacks: Patio covers shall have a minimum setback of 5 feet to the side and rear property lines and a minimum 20-foot setback to the front property line when located in the front yard. Setbacks are measured to the supporting posts.
5. When the above setbacks are observed, planning approval will not be required. Any deviation from the above setbacks will require the review and approval of the Planning Division. Indicate if property has a zero lot line.

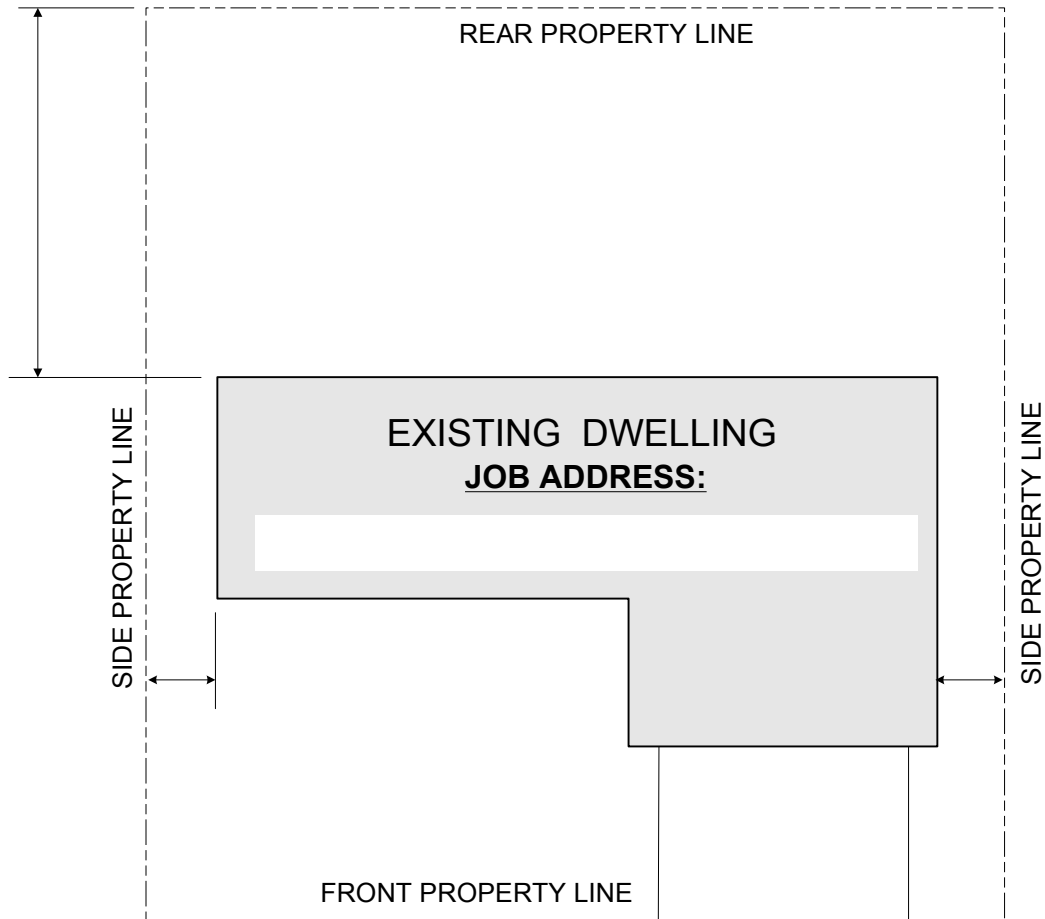

PROPERTY OWNER: _____

ADDRESS: _____ CITY: _____ STATE: _____ ZIP: _____



CITY OF SANTA CLARITA

BUILDING & SAFETY DIVISION

23920 Valencia Boulevard, Suite 140

Santa Clarita, CA 91355 (661) 255-4935

TYPICAL ROOFED PATIO COVER

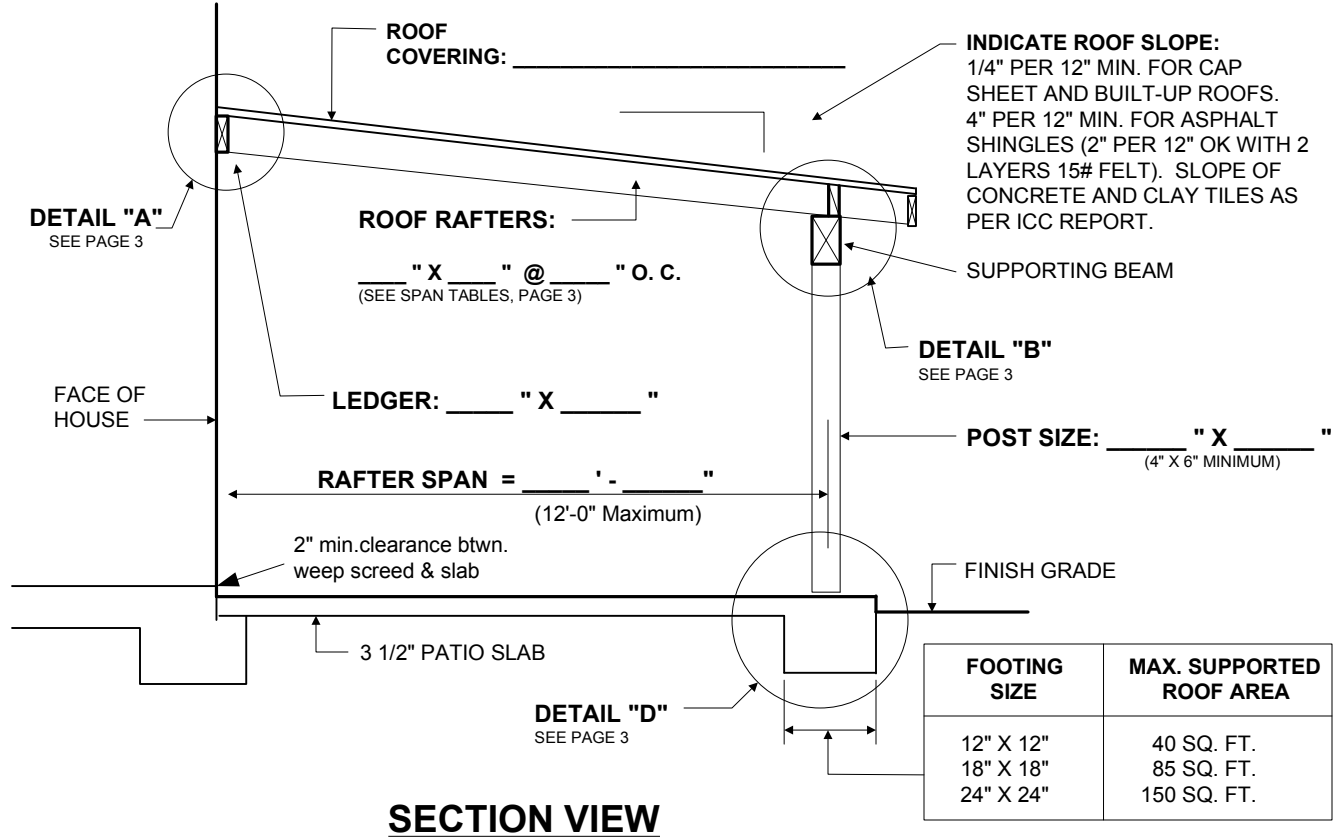

FOOTING SIZE	MAX. SUPPORTED ROOF AREA
12" X 12"	40 SQ. FT.
18" X 18"	85 SQ. FT.
24" X 24"	150 SQ. FT.

(CIRCLE FOOTING SIZE TO BE USED, ALL FOOTINGS ARE 12" DEEP)

ALLOWABLE ROOF AREA SUPPORTED AT EACH KNEE BRACE

ROOF ASSEMBLY	
LIGHT*	HEAVY*
35 sq. ft.	22 sq. ft.

* See Sheet 4 for Definitions

MAXIMUM OVERHANG = 1/3 OF SPAN OF BEAM WITH 48" MAX. AND AT LEAST 3 FEET FROM PROPERTY LINE

DETAIL "C"
SEE PAGE 3

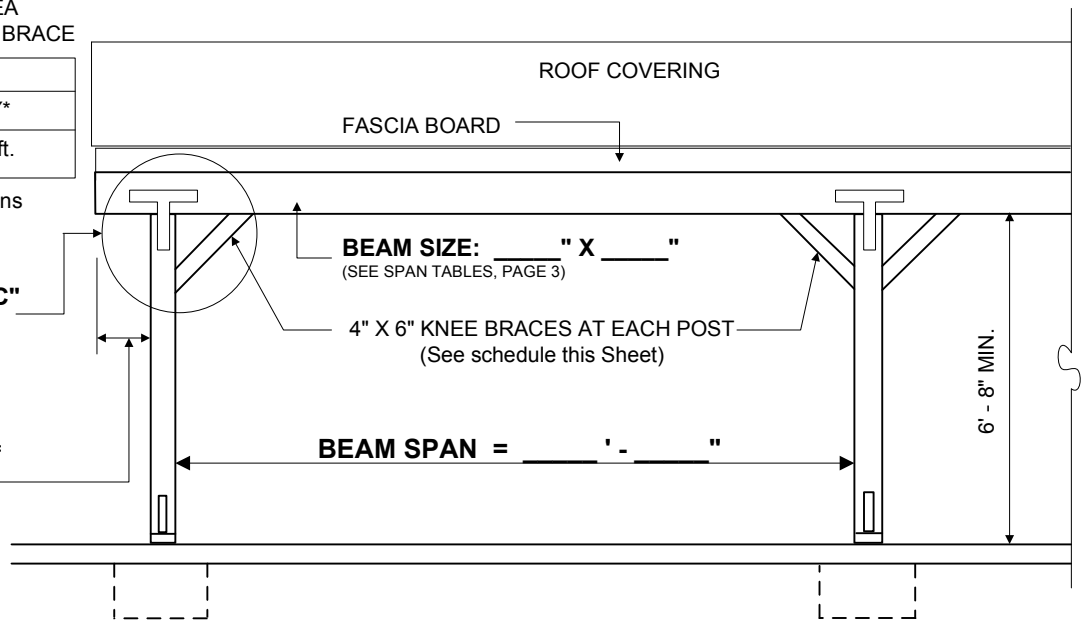

CITY OF SANTA CLARITA
BUILDING & SAFETY DIVISION
 23920 Valencia Boulevard, Suite 140
 Santa Clarita, CA 91355 (661) 255-4935



TYPICAL ROOFED PATIO COVER

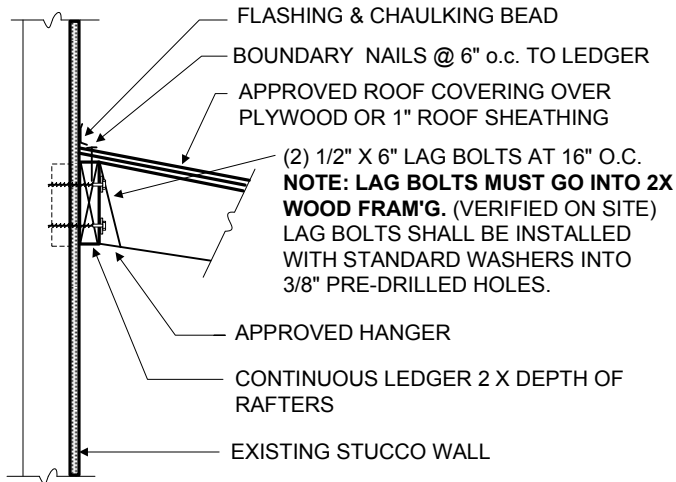

LEDGER CONNECTION - "A"

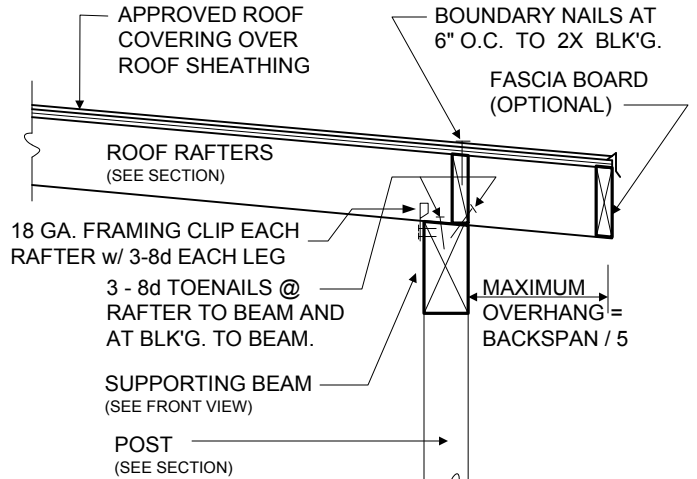

RAFTER TO BEAM DETAIL - "B"

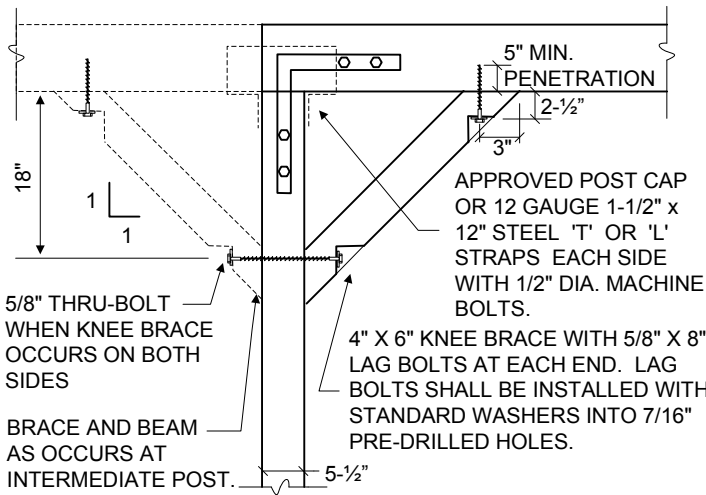

KNEEBRACING DETAIL - "C"

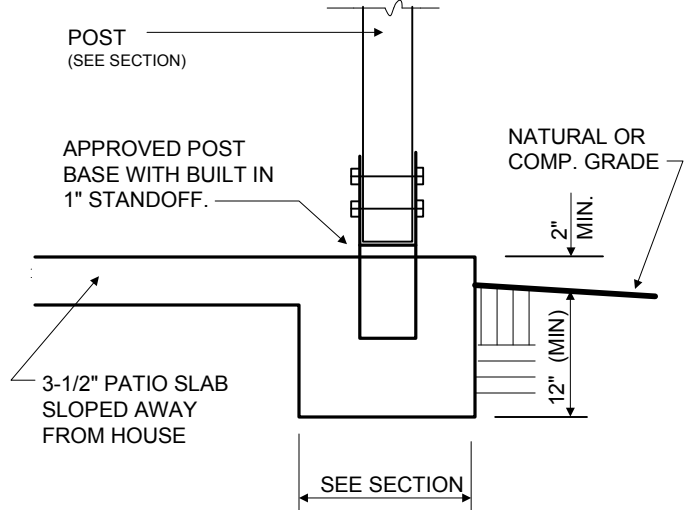

TYPICAL FOOTING DETAIL - "D"

ALLOWABLE RAFTER SPANS								BEAM SPANS		
Rafter Size	Rafter Spacing	Light Roof	Heavy Roof	Rafter Size	Rafter Spacing	Light Roof	Heavy Roof	Beam Size	LIGHT ROOF	HEAVY ROOF
2" x 4"	12"	8'-4"	7'-9"	4" x 4"	16"	10'-0"	9'-4"	4" x 4"	5'-0"	4'-0"
	16"	7'-6"	7'-0"		24"	8'-8"	8'-2"	4" x 6"	7'-0"	6'-0"
	24"	6'-6"	6'-2"		32"	7'-10"	7'-4"	4" x 8"	10'-0"	8'-6"
2" x 6"	16"	12'-0"	11'-2"	4" x 6"	24"	12'-0"	12'-0"	4" x 10"	12'-0"	10'-6"
	24"	10'-0"	9'-8"		32"	12'-0"	11'-6"	4" x 12"	14'-0"	12'-6"
	32"	9'-0"	8'-2"		48"	10'-10"	10'-2"	4" x 14"	16'-0"	14'-0"
2" x 8"	24"	12'-0"	12'-0"	4" x 8"	24"	12'-0"	12'-0"	6" x 8" #1	13'-0"	12'-0"
	32"	11'-6"	10'-4"		32"	12'-0"	12'-0"	6" x 10" #1	16'-6"	15'-0"
	48"	9'-4"	8'-4"		48"	12'-0"	12'-0"	6" x 12" #1	20'-0"	18'-6"



CITY OF SANTA CLARITA

BUILDING & SAFETY DIVISION
 23920 Valencia Boulevard, Suite 140
 Santa Clarita, CA 91355 (661) 255-4935

TYPICAL ROOFED PATIO COVER

INSTRUCTIONS:

1. A building permit for a patio cover may be obtained using these City standard drawings. Simply fill in the blanks and information requested on these plans.
2. Complete an "Application for a Building Permit" and present it with these plans to a permit specialist.
3. Deviation from the construction and designs shown in these drawings will require complete plans and details and must be reviewed by a City Plan Check Engineer prior to obtaining a building permit. Approval by a Registered Architect or Engineer may be required.

GENERAL INFORMATION:

1. A patio cover is a one-story structure that does not exceed 12-feet in height above the adjacent grade.
2. Patio covers shall be used for recreational, outdoor living purposes only and shall not be used as carports, garages, storage rooms or habitable rooms.
3. Patio covers must be accessory to a single-family dwelling or individual dwelling unit in a multiple-dwelling building.
4. Patio covers may be partially enclosed provided the area of the longer wall and one additional wall is at least 65% open. Openings may be enclosed with insect screening or readily removable plastic (translucent or transparent) up to 1/8-inch thick. Framed windows are not permitted.
5. Construction details in this standard may not comply with Fire Hazard Zone construction requirements. See www.santa-clarita.com for more information on Fire Hazard Zones and construction requirements.

MATERIALS:

1. WOOD shall be grade marked Douglas Fir Larch No. 2 or better.
2. CONCRETE shall have a minimum strength of 2500 psi in 28 days.
3. FRAMING HARDWARE shall be ICC approved for the intended use and installed per manufacturers' specifications using all recommended fasteners.
4. ROOF SHEATHING shall be continuous over 2 or more rafter spans, face grain shall be perpendicular to supports and maximum span shall be as follows:

SHEATHING	SPAN RATING	MAX. SPAN	NAILING
1/2" CDX Plywood	24/0	24" O.C.	8d common or deformed shank
5/8" CDX Plywood	40/20	32" O.C.	10d common or 8d deformed shank
3/4" CDX Plywood	48/24	36" O.C.	10d common or 8d deformed shank
1 1/8" CDX Plywood	60/48	48" O.C.	10d common or 8d deformed shank
1 x nominal lumber		24" O.C.	2 - 10d at each lap

(all nail spacing for plywood sheathing shall be 6" on center at edges and 12" on center in field)

5. ROOF COVERING shall be Class B or better fire retardant.
6. **LIGHT ROOF ASSEMBLIES** include asphalt or fiberglass shingles, cap sheets, built-up roof and hot-mopped roofs without stucco ceiling or soffits.
7. **HEAVY ROOF ASSEMBLIES** include concrete tile roofing (10 psf max.) without stucco ceiling, or lightweight roofing with stucco ceiling.

REQUIRED INSPECTIONS:

1. FIRST INSPECTION shall be after excavation for the footings (before any concrete is poured).
2. SECOND INSPECTION shall be the framing inspection when all framing has been completed. The roof sheathing and nailing will be inspected at this time.
3. THIRD INSPECTION will be the final inspection after the roof covering has been installed. Exposed wood has been weather protected.

PLEASE READ AND SIGN:

The owner and/or contractor, as applicant for this permit, has read and understands the information on this page and agrees to construct the proposed patio cover as shown on these plans.

Signature of Applicant _____ Date: _____



CITY OF SANTA CLARITA

BUILDING & SAFETY DIVISION
23920 Valencia Boulevard, Suite 140
Santa Clarita, CA 91355 (661) 255-4935